

Supra 0-10V expansion kit installation guide

The Variable DC Expansion Kit (K210050) allows you to connect equipment to your Supra that requires a 0 to 10 V input, such as variable frequency drives or modulating valves.

The expansion kit installs in seconds and has four outputs you can configure for cooling or heating. Each output has its own settings and functions the same as the Supra's other variable stages.

The Supra expansion kit is available for Supras that have an expansion connector and firmware version 2.00 or later. The expansion connector is on the main Supra circuit board and is labeled CON6. For more information, see the following diagram.

Installing the expansion kit

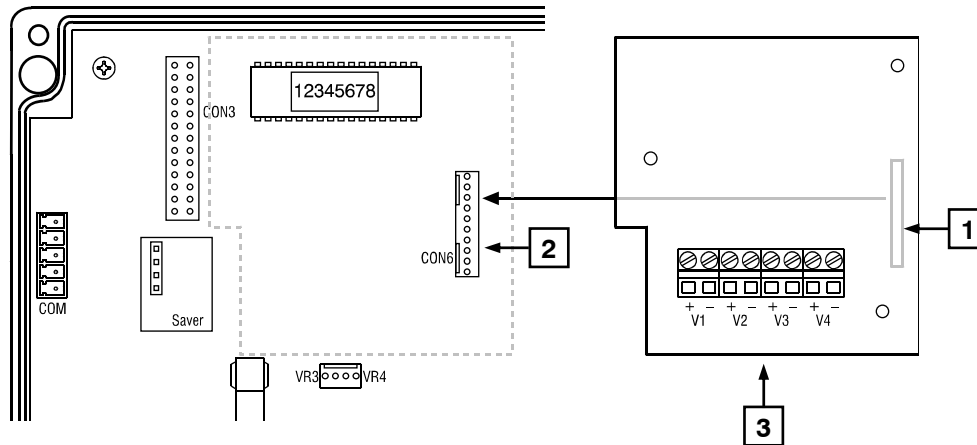

- 1** Expansion board connector (on the bottom) – connect this to the connector on the Supra.
- 2** Supra connector (CON6) – connect the expansion board to this connector.
- 3** Variable DC terminals (V1 to V4) – connect equipment that requires 0-10 volt input to these terminals.

NOTE

All the negative terminals on the expansion board have a common connection.

To install the expansion kit

Before installing the expansion kit or servicing the Supra, switch OFF the power to the Supra at the source.

1. Switch off the power to the Supra.
2. Loosen the screws in the front cover and then swing it open.
3. Connect the expansion board to the connector on the Supra. Make sure the nylon supports sit properly in the holes of the Supra circuit board.
4. Connect the equipment to the expansion kit as shown below.

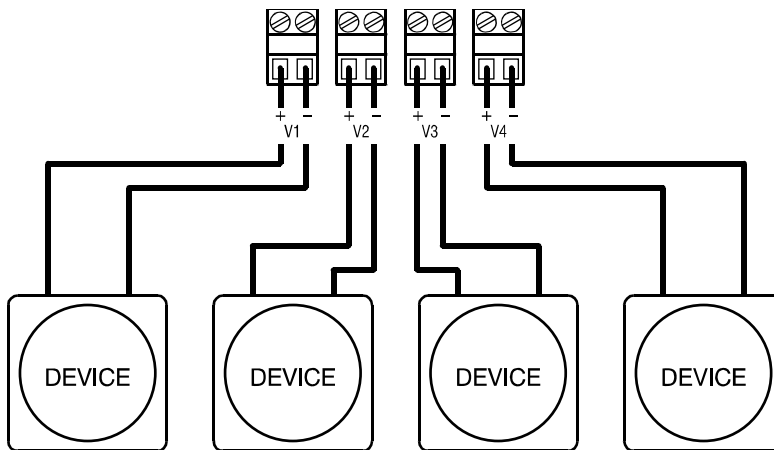

5. Verify all the wires are properly connected to their correct locations.
6. Switch on the power to the Supra and verify the control and equipment operates properly.

The Supra's test mode is useful for testing equipment. For more information, read the Testing section in the **Supra user manual**.

If the Supra or equipment does not operate properly, check the wiring and connections. If the Supra still does not operate properly, contact your dealer.

7. Close the cover and then tighten the screws.

Phason Inc.
2 Terracon Place
Winnipeg, Manitoba, Canada
R2J 4G7

Phone: 204-233-1400
Fax: 204-233-3252

E-mail: support@phason.ca
Web site: www.phason.ca