

# Local Environment Monitor installation guide

The Local Environment Monitor (LEM) works with OMNI-Site Watcher to continuously monitor critical conditions and notify OMNI-4000 of any alarm conditions. Using multiple Local Environment Monitors, you can monitor conditions in every room or zone at your site.

The LEM automatically monitors its supply voltage and comes with a 30-foot temperature probe for monitoring outdoor or ambient temperatures. In addition, the Local Environment Monitor can also monitor humidity, pulse counts, auxiliary inputs, and digital inputs. The auxiliary and digital inputs allow you to customize your monitoring system to monitor virtually anything you want. The table below explains the LEM inputs and their uses.

Input	Uses
TEMP	Monitoring outdoor or ambient temperatures
HUM	Monitoring humidity
DC	Monitoring the DC voltage supply
COUNT	Monitoring pulse counts, such as a water meter with a pulse output
AUX1 and AUX2	Monitoring additional temperature probes, including 3K, 1K, and HTP probes Monitoring humidity Monitoring other variable input sensors such as static pressure, pH, and raw data
IN1 to IN6	Monitoring power failures Monitoring dry (unpowered) contacts from relays or switches, such as door contacts (open/closed) or pressure switches (low/high)

## Features

- ◆ Twelve customizable monitoring inputs
- ◆ Easy installation
- ◆ Low-maintenance design
- ◆ Alarm relay
- ◆ Temperature probe with 30-foot cable, extendable to 500 feet
- ◆ Rugged enclosure (corrosion resistant, water resistant, and fire retardant)
- ◆ Two-year limited warranty

## Electrical ratings

- ◆ Input: 10 to 14 VDC, 100 mA
- ◆ Alarm Relay: 0.2 A at 230 VAC, 0.4 A at 24 VAC, 2.0 A at 30 VDC

The Local Environment Monitor requires a Phason Regulated Power Supply (RPS). One RPS can provide power for up to 11 Local Environment Monitors. For more information, see the **RPS installation guide** or contact your dealer.

## Optional accessories

### Relative Humidity Sensor (RHS/RHS-P)

The RHS model monitors humidity at the LEM; the RHS-P has a 100-foot weather and UV-resistant cable for monitoring remote locations.

### High Temperature Probe (HTP)

The HTP monitors temperatures ranging from 86 to 302°F (30 to 150°C). The probe comes with a 6-foot cable and can be extended up to 500 feet using extension cable.

### Phase Detection Sensor (PDS-1)

The PDS-1 monitors three-phase power for a single line. Using multiple PDS-1s, you can monitor additional circuits, zones, or rooms at your site. You can connect up to six PDS-1s to a single LEM.

### Power Loss Sensor (PLS-1)

The PLS-1 monitors single-phase, 120 VAC power for a single line. You can connect up to six PLS-1s to a single LEM.

### Standard 3K temperature probe

Standard temperature probes monitor temperatures ranging from -49 to 122°F (-45 to 50°C). The probes are available in 1, 6, 30, 75, or 150-foot cable lengths and can be extended up to 500 feet using extension cable.

### Extension cable

Extension cable is for extending temperature probes to remote locations and is available in 500-foot lengths.

## Installing the Local Environment Monitor

Read all the steps before installing the Local Environment Monitor and then follow them in the order they are listed.

### Parts list

The following items are included with the Local Environment Monitor:

- ◆ Local Environment Monitor
- ◆ Thirty-foot temperature probe
- ◆ Mounting screws (4)
- ◆ Installation guide

In addition to the parts included, you need to provide the following:

Item	Notes
Power supply	Phason Regulated Power Supply (RPS)
Power cable	Enough to go from the power supply to the LEM
Watertight strain reliefs or conduit connectors	Use at all cable entry points
Communication cable	Twisted pair cable, category 3 (CAT3) or category 5 (CAT5) Unshielded twisted pair (UTP) or shielded twisted pair (STP) cable* Four pair recommended
	If you are using STP cable, you must follow the specific instructions in <b>Service Bulletin 24—Using shielded twisted pair (STP) cable to connect Phason networkable devices</b> . For more information, contact Phason Customer Support.

### Precautions, guidelines, and warnings



The Local Environment Monitor must be installed by a qualified electrician.

Before installing or servicing the Local Environment Monitor, switch OFF the power supply at the source.

Install the Local Environment Monitor and all equipment connected to it according to local electrical codes.

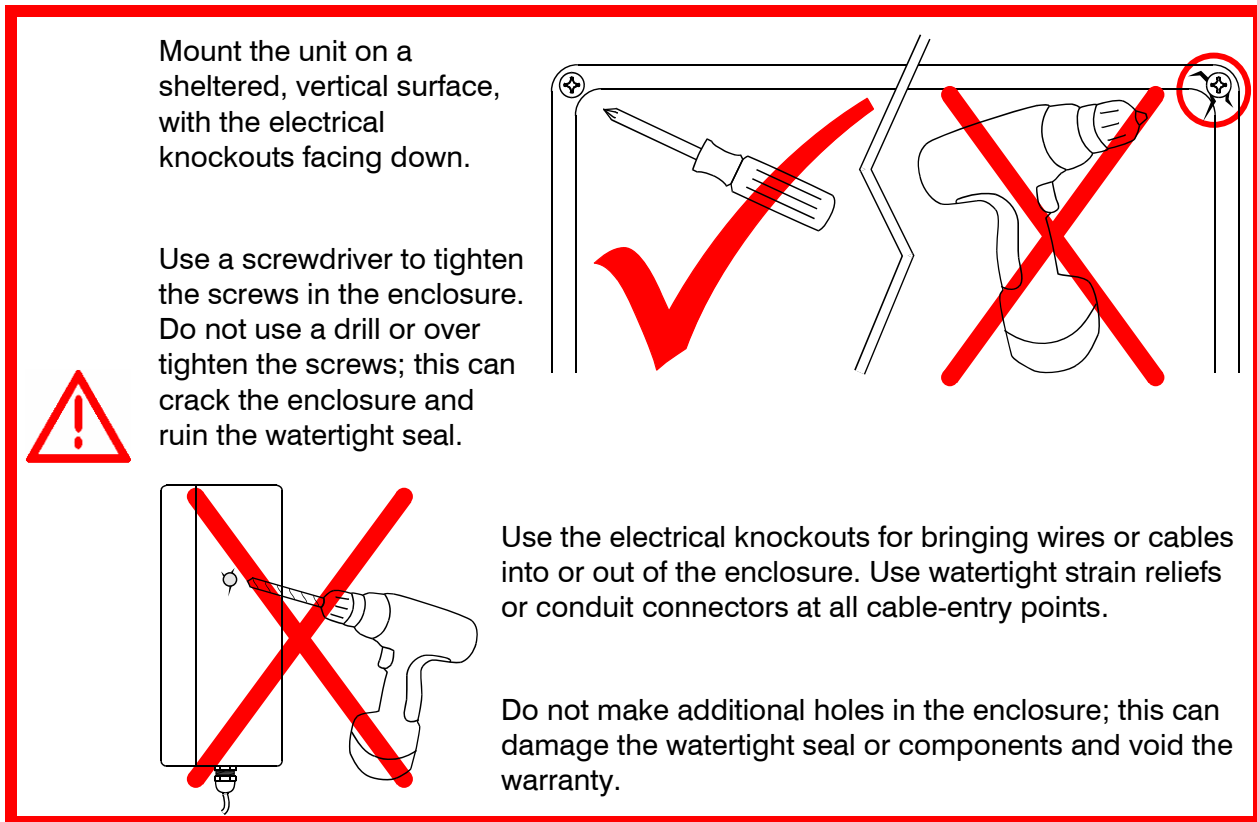

### Routing data wires

Routing data wires in the same conduit as, or beside AC power cables, can cause electrical interference, erratic readings, and/or improper control. Data wires include **all** of the following:

- ◆ Temperature probe and humidity sensor cables
- ◆ Actuator feedback (potentiometer) wires
- ◆ Data communication wires, including RS-232/RS-485
- ◆ Any cable or wire that does not provide AC power

### Guidelines for routing data wires

- ◆ Do not run the wires in the same conduit as AC power cables.
- ◆ Do not run the wires beside AC power cables or near electrical equipment.
- ◆ When crossing other cables or power lines, cross them at a 90-degree angle.

If in doubt, **do not run any wire or cable that is not an AC-power wire** inside the same conduit or beside other AC-power wires.

## Local Environment Monitor layout

### Auxiliary terminal block

You can connect a standard 3K temperature probe, High Temperature Probe, or Relative Humidity Sensor to this terminal block.

### DC terminal blocks (two)

Connect the incoming DC power to one of these two terminal blocks.

### Alarm relay terminal block

You can connect the Alarm Manager for OMNI-Alert to this terminal block.

### Humidity terminal block

You can connect a humidity sensor to this terminal block.

### Input connection label

Use this label to write down the descriptions of what is connected to the input terminals

### Temperature terminal block

You can connect a standard 3K temperature probe or a High Temperature Probe to this terminal block.

### Pulse count terminal block

You can connect dry contacts to this terminal block to count switching activity.

### Auxiliary terminal block

You can connect a standard 3K temperature probe, High Temperature Probe, or Relative Humidity Sensor to this terminal block.

### Digital input terminal blocks (six)

You can connect switches such as door contacts or pressure switches to these terminal blocks.

### Address label

This is the LEM's address on the OMNI-4000 system. Write down this address, the person installing the software will need it.

### Termination resistors

If there are any devices on this communication channel after the LEM, then use wire cutters to remove only these two resistors (R1,R2).

### Communication socket

Plug the communication connector into this socket.

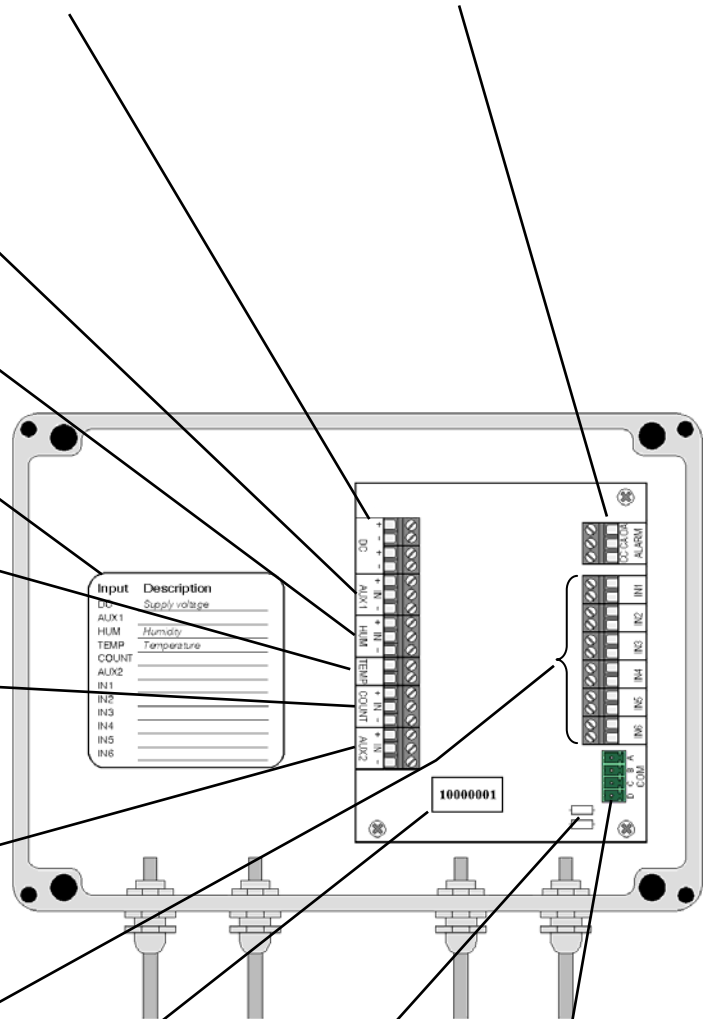

## Mounting Local Environment Monitors

When selecting a location for a Local Environment Monitor, follow the guidelines below.

- ◆ Mount the unit on a sheltered, vertical surface, with the electrical knockouts facing down.
- ◆ Select a location that is convenient and allows you to mount the temperature probe and other sensors in desirable locations.

### To mount Local Environment Monitors

1. Remove the cover from the enclosure.
2. Fasten the unit to a secure surface using the four screws provided.

## Connecting temperature probes to temperature inputs

Follow the instructions below to connect a Phason standard 3K temperature probe to the temperature (**TEMP**) input.

For High Temperature Probes, follow the steps on page 7.



When routing the temperature probe cables, do not run them in or along the same conduit as AC-power lines. Follow the guidelines on page 4.

You can extend probe cables up to 500 feet. For more information, contact your dealer or Phason.

### To connect temperature probes to temperature inputs

Connect the temperature probe to the **TEMP** terminals as shown below.

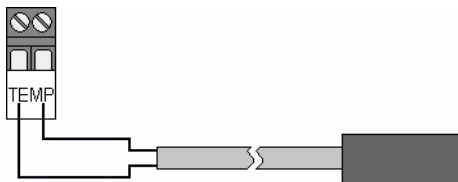

## Connecting temperature probes to auxiliary inputs

Follow the instructions below to connect a Phason standard 3K temperature probe or High Temperature Probe to the auxiliary (**AUX1** and **AUX2**) inputs.

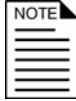

When routing the temperature probe cables, do not run them in or along the same conduit as AC-power lines. Follow the guidelines on page 4.

You can extend probe cables up to 500 feet. For more information, contact your dealer or Phason.

### To connect temperature probes to auxiliary inputs

1. Connect the probe to the **IN** and **—** terminals as shown below.
2. Place the jumper in the position shown below.

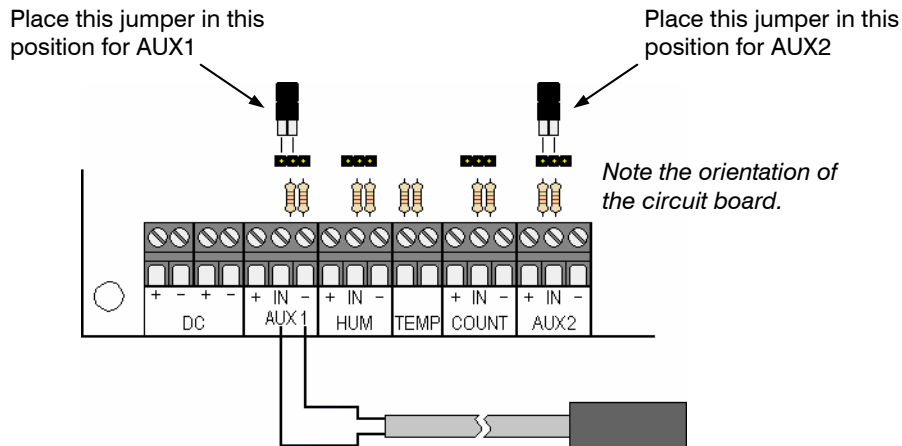

## Connecting Relative Humidity Sensors

Follow the instructions below to connect a Phason Relative Humidity Sensor (RHS or RHS-P) to any of the humidity (**HUM**) or auxiliary (**AUX1** and **AUX2**) inputs.

If you are using one humidity sensor, connect it to the humidity input. If you are using two or three humidity sensors, connect the second and third sensors to the auxiliary inputs.

**To connect Relative Humidity Sensors**

1. Connect the black sensor wire to the - terminal.
2. Connect the red sensor wire to the + terminal.
3. Connect the remaining sensor wire to the **IN** terminal.

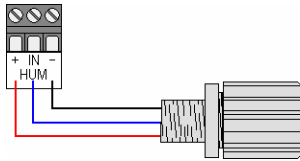

4. If you are connecting the sensor to one of the auxiliary terminals (**AUX1** or **AUX2**), then position the jumper as shown below.

Place this jumper in this position for AUX1

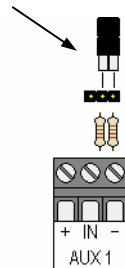

Place this jumper in this position for AUX2

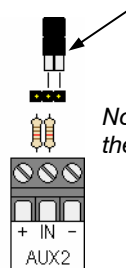

Note the orientation of the circuit board.

**Connecting water meters to pulse counter inputs**

You can connect any water meter that has a dry contact to the pulse counter (**COUNT**) input. When selecting a water meter, you need to consider the maximum pulse rate at the expected *peak* flow rate of the water line. The peak flow rate is the maximum flow rate of the water line.

Expected flow rate	Suggested water meter pulse rate
Low	10 pulses per unit
Medium	1 pulse per unit
High	1 pulse per 10 units
Very high	1 pulse per 100 units

If you do not expect a peak flow rate of more than one unit (US gallon, Imperial gallon, or litre) per second, choose a water meter that puts out 10 pulses per unit. If you expect a medium or high flow rate, select a water meter that puts out one pulse per unit or one pulse per 10 units. For a very high flow rate, select a water meter that puts out one pulse per 100 units.

The Local Environment Monitor can count up to 65535 pulses per sample duration. After 65535 pulses, the counter starts again at 0. This means that the water meter you select must put out less than 65535 pulses for each sample duration. For more information about sample duration, see the OMNI-Site Watcher user manual.

### For example

You have a water meter that puts out 10 pulses per gallon and the expected peak flow rate is 250 gallons per minute. There would be 2500 pulses per minute (250 gallons  $\times$  10 pulses per gallon) at the peak flow rate.

The water meter would put out 75,000 pulses at the peak flow rate for a sample duration of 30 minutes (30 minutes  $\times$  2500 pulses per minute). After 65535 pulses, the Local Environment Monitor would reset to 0 and interpret the total number of pulses as 9465. Your count would be incorrect.

The solution for this problem is to select a water meter that does not put out as many pulses per unit. A meter that puts out one pulse per unit would count 7500 pulses at the peak flow rate during the 30-minute sample duration.

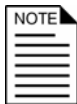

If you are using a Power Block with OMNI-Water to measure water usage, follow the instructions to **connect water meters to Power Blocks and Local Environment Monitors**.

If you are not using a Power Block with OMNI-Water, follow the instructions to **connect a water meter to pulse counter inputs**.

### To connect water meters to pulse counter inputs

1. Connect two wires to the water meter pulse outputs. For information about your water meter pulse outputs, see the documentation that came with your water meter.
2. Connect one wire to the **IN** terminal of the **COUNT** terminal block.
3. Connect the remaining wire to the **-** terminal of the **COUNT** terminal block.

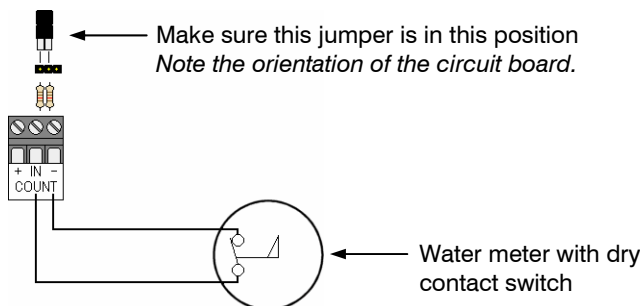

### To connect water meters to Power Blocks and Local Environment Monitors

1. Connect two wires to the water meter pulse outputs. For information about your water meter pulse outputs, see the documentation that came with your water meter.
2. Connect one wire to the **PULSE** terminal on the Power Block and the **IN** terminal of the **COUNT** terminal block on the Local Environment Monitor.
3. Connect one wire to the **GND** terminal on the Power Block and the **-** terminal of the **COUNT** terminal block on the Local Environment Monitor.

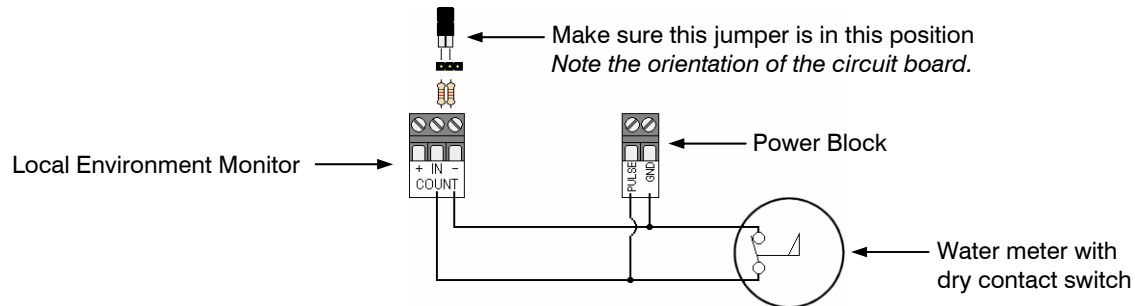

### Connecting sensors to the digital inputs

The digital inputs are for monitoring power failures, magnetic door contact switches, pressure switches, or any other dry contact switch or relay. You can connect these devices to any of the digital inputs (**IN1** to **IN6**).



Do not connect live circuits to the digital inputs. This will damage the Local Environment Monitor and void the warranty.

### To connect sensors to digital inputs

Connect the sensor to any of the **IN1** to **IN6** terminals as shown below.

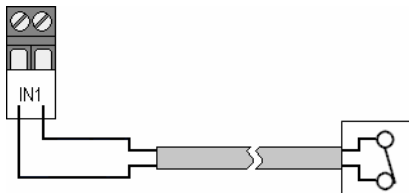

## Connecting Local Environment Monitors to the power supply

The Regulated Power Supply provides 13.6 VDC and can supply power to up to 11 Local Environment Monitors. With an auxiliary 12 V battery and the RPS Battery Cable, the RPS can provide battery backup to your Local Environment Monitors.

For more information about the Regulated Power Supply or the RPS Battery Cable, see the **RPS installation guide** or contact your dealer.

### To connect a Local Environment Monitor to the power supply

Connect the LEM to the power supply as shown in the appropriate diagram below.

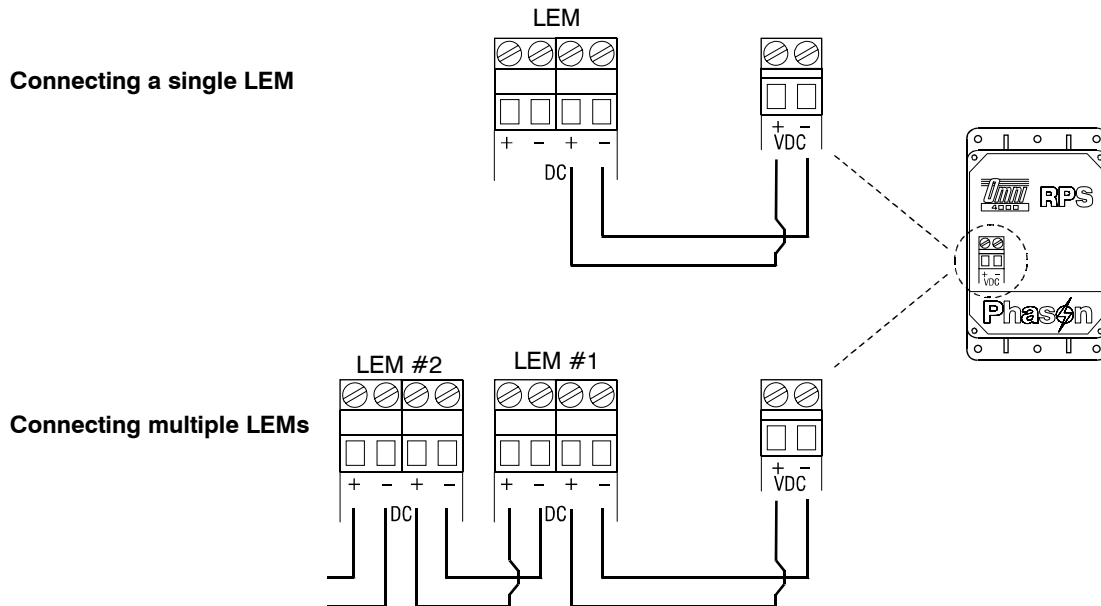

For information about connecting battery backup, see the **RPS Battery Cable installation guide**.

## Connecting the communication wires

NOTE

Connect the communication wires according to the instructions in the **RS-485A installation guide**.

If you are also using an OMNI Alarm Manager (OAM), see the **OAM installation guide** for additional installation instructions.

There are three possible connector types on Phason devices. The four-positions, **A B C D**, are common to all models. Newer models have five positions and include **E** for common reference wiring. The six-position connectors that include position **1** are included on the RS-485A and OMNI Alarm Manager (OAM) only. The proper connector alignment is shown below.

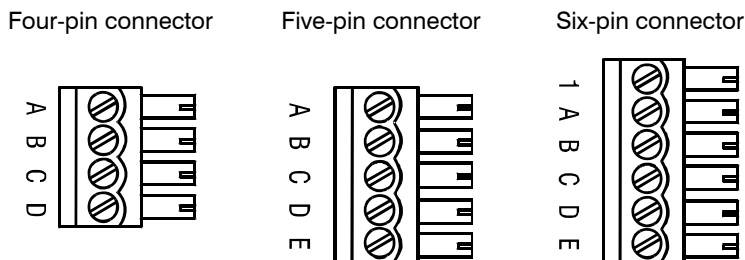

Using consistent wiring helps eliminate communication connection errors and makes troubleshooting much easier. Positions **A/B** and **C/D** must be twisted pairs. Use the wire colors shown below when connecting all devices to the communication system.

Wire function	RS-485A wire colors	First device	All remaining devices
<b>1</b> alarm signal <sup>①</sup>	<b>1</b> white/green	<b>1</b> white/green	<b>1</b> white/green
<b>A</b> communication	<b>A</b> blue	<b>A</b> blue	<b>A</b> blue
<b>B</b> communication	<b>B</b> white/blue	<b>B</b> white/blue	<b>B</b> white/blue
<b>C</b> communication	<b>C</b> orange	<b>C</b> orange	<b>C</b> orange
<b>D</b> communication	<b>D</b> white/orange	<b>D</b> white/orange	<b>D</b> white/orange
<b>E</b> common reference <sup>②</sup>	<b>E</b> green	<b>E</b> green	<b>E</b> green

<sup>①</sup> For OMNI systems with an OMNI Alarm Manager only

<sup>②</sup> Not available on all models. IF there is no **E** position, connect common reference to the **DC** – terminal. For more information, see the RS-485A installation guide.

## Common mistakes in communication wiring

- ◆ **Not using the correct type of communication cable**—the communication cable must be twisted pair cable, category 3 (CAT3) or category 5 (CAT5). You can use either unshielded twisted pair (UTP) or shielded twisted pair (STP) cable. Phason does not recommend other types of wire.

	<p>If you are using STP cable, you must follow the specific instructions in <b>Service Bulletin 24—Using shielded twisted pair (STP) cable to connect Phason networkable devices</b>. For more information, contact Phason Customer Support.</p>
---	--

- ◆ **Not continuing the communication wiring properly**—all the devices on the communication channel must be connected in series (in a daisy-chain) and the wire must be continued properly from one device to the next. When continuing the communication wiring from one device to the next, the wires must be connected as shown below.

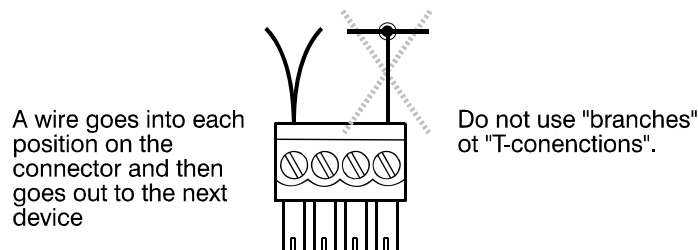

- ◆ **Not terminating the last device on the communication channel**—on all systems, the last device on the communication channel must have the termination resistors in place or a termination module installed.

The termination resistors are located on the circuit board of all OMNI-4000 devices. You must remove the termination resistors from all devices, except the last one on the communication channel. For the location of the termination resistors on the LEM, see **Local Environment Monitor layout** on page 5. For more information about the location of termination resistors on other devices, see the installation guide for the specific product.

If you remove the termination resistors from the last device by mistake, you will have to install a Termination Module on that device. The Termination Module connects to the communication socket on the last device. For information about Termination Modules, contact your dealer or Phason Customer Support.

- ◆ **Running the communication cable in the same conduit as, or beside AC power cables**—routing communication cable in the same conduit as, or beside AC power cables, can cause electrical interference and communication failures. Follow the guidelines below when routing communication cable.
  - ◆ Do not run the cable in the same conduit as AC power cables.
  - ◆ Do not run the cable beside AC power cables or near electrical equipment.
  - ◆ When crossing other cables or power lines, cross them at a 90-degree angle.

## Completing the installation

Completing the installation means verifying that all the sensors and wires are mounted and connected properly and then fastening the cover to the enclosure.

### Fasten the cover to the Local Environment Monitor

1. Make sure all the sensors are mounted properly.
2. Make sure strain reliefs are used at all cable entry points.
3. Make sure each wire is connected to its proper location.
4. Fasten the cover to the unit using the four cover screws.

## Service and technical support

Your dealer will be happy to answer all technical questions. Before contacting your dealer or Phason, check the following:

- ◆ Read this manual and verify that all sensors are connected to their proper locations and that all jumpers are in their proper positions.
- ◆ Make sure the communication wiring is correct. For more information, see **Connecting the communication wires** on page 12.
- ◆ If you still have a problem, collect the following information:
  - ◆ Any messages displayed by the OMNI-Site Watcher software
  - ◆ A description of the problem
  - ◆ A description of what you were doing before the problem occurred

## Limited warranty

This warranty applies only to the Local Environment Monitor (LEM). If you need warranty service, return the product and original proof of purchase to your dealer.

Phason Inc. (Phason) warrants this product subject to the following terms and conditions.

This warranty is valid only to the original purchaser of the LEM, for two years from the manufacturing date. The manufacturing date is stated in the first eight digits of the serial number in the form year-month-day.

Phason hereby warrants that should the LEM fail because of improper workmanship, Phason will repair the LEM, effecting all necessary parts replacements without charge for either parts or labor.

### Conditions

- ◆ Installation must be done according to our enclosed installation instructions.
- ◆ The LEM must not have been previously altered, modified, or repaired by anyone other than Phason.
- ◆ The LEM must not have been involved in an accident, misused, abused, or operated or installed contrary to the instructions in our user and/or installation manuals. Phason's opinion about these items is final.
- ◆ The person requesting warranty service must be the original purchaser of the LEM, and provide proof of purchase upon request.
- ◆ All transportation charges for products submitted for warranty must be paid by the purchaser.

Except to the extent prohibited by applicable law, no other warranties, whether expressed or implied, including warranties of merchantability and fitness for a particular purpose, shall apply to the LEM. Any implied warranties are excluded.

Phason is not liable for consequential damages caused by the LEM.

Phason does not assume or authorize any representatives, or other people, to assume any obligations or liabilities, other than those specifically stated in this warranty.

Phason reserves the right to improve or alter the LEM without notice.

Phason Inc.  
2 Terracon Place  
Winnipeg, Manitoba, Canada  
R2J 4G7

Phone: 204-233-1400  
Fax: 204-233-3252

E-mail: [support@phason.ca](mailto:support@phason.ca)  
Web site: [www.phason.ca](http://www.phason.ca)