

## RS-485-HD installation guide

The RS-485-HD Converter allows your computer to communicate with devices that use half-duplex communication.

The RS-485-HD includes the following items.

- ◆ Instruction sheet
- ◆ RS-485-HD Converter
- ◆ Software driver CD
- ◆ USB cable

### Communication overview

A half-duplex communication channel is a continuous line of cable connecting all devices in the series, in other words, a “daisy chain”. A half-duplex communication channel can have up to 32 devices.

The last device on either end of the communication channel must have the termination resistors or jumper in place—this is called terminating the device. For the location of the resistors or jumper, read the installation guide for the particular device.

In the following example, the RS485 and the "last device" must be terminated.

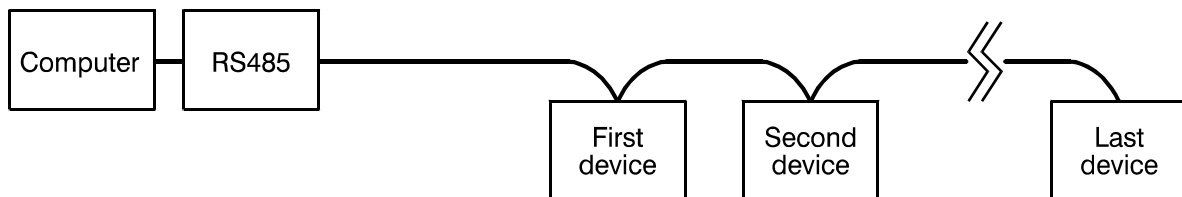

In the following example, the "last device" *at each end* of the channel must be terminated.

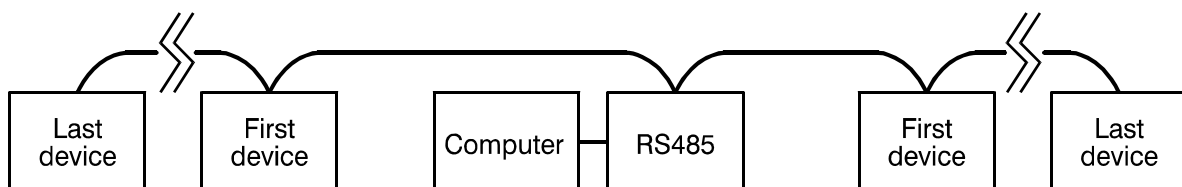

## Communication cable requirements

The following types of cable are acceptable:

- ◆ Unshielded twisted pair (UTP), category 3 (CAT3) or category 5 (CAT5)
- ◆ Shielded twisted pair (STP), CAT3 or CAT5

Phason does not recommend other types of wire.

## Installing the RS-485-HD Converter

There are three steps to installing the RS-485-HD Converter:

1. Connecting the communication wiring
2. Connecting the RS-485-HD to the computer
3. Installing the software drivers on the computer

## Connecting the communications

Read **Proper connector alignment and wiring** below and **Common mistakes in communication wiring** on page 3 before connecting the communication wiring.

### Proper connector alignment and wiring

The RS485-HD has a three-position connector with the labels **A**, **B**, and **E**. Some devices have the labels **Rx**, **Tx**, and **GND**. The different labels correspondent as follows.

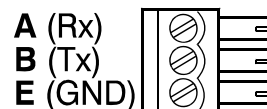

Using consistent wiring helps eliminate errors and makes troubleshooting much easier. Use the following wire colors when connecting all devices to the communication system.

Wire function	RS485-HD wire colors	First device	All remaining devices
<b>A</b> communication	<b>A</b> blue	<b>A</b> blue	<b>A</b> blue
<b>B</b> communication	<b>B</b> white/blue	<b>B</b> white/blue	<b>B</b> white/blue
<b>E</b> ground	<b>E</b> green	<b>E</b> green	<b>E</b> green

## Common mistakes in communication wiring

- ◆ **Not using the correct type of communication cable** – the communication cable must be twisted pair cable, category 3 (CAT3) or category 5 (CAT5). You can use either unshielded twisted pair (UTP) or shielded twisted pair (STP) cable. Phason does not recommend other types of wire.

There are additional guidelines to follow when using STP cable. For more information, read **Using shielded twisted pair (STP) cable** below.

- ◆ **Not continuing the communication wiring properly** – all the devices on the communication channel must be connected in series (in a daisy-chain) and the wire must be continued properly from one device to the next. When continuing the communication wiring from one device to the next, the wires must be connected as shown in the following diagram.

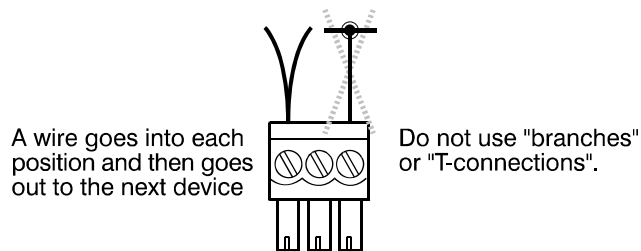

- ◆ **Not terminating the last device on the communication channel** – on all systems, the last device on either end of the communication channel must have the termination resistors or jumper in place—this is called terminating the device. For the location of the resistors or jumper, read the installation guide for the particular device.
- ◆ **Running the communication cable in the same conduit as, or beside AC power cables** – routing communication cable in the same conduit as, or beside AC power cables, can cause electrical interference and communication failures. Follow the guidelines below when routing communication cable.
  - ◆ Do not run the cable in the same conduit as AC power cables.
  - ◆ Do not run the cable beside AC power cables or near electrical equipment.
  - ◆ When crossing other cables or power lines, cross them at a 90-degree angle.

## Using shielded twisted pair (STP) cable

The advantage of using STP cable is that it can improve communications by reducing electromagnetic interference.

The drawback of STP cable is that it requires more care during installation. If the shielding is connected incorrectly, shielded cable can cause more problems than it solves.

### How to install shielded cable

When installing shielded cable, you must connect the shielding to the building ground at one end only. Phason recommends connecting the cable to the building ground near the computer or RS485-HD.

When connecting the devices along the communication channel (daisy-chain), connect the shielding of the incoming cable to the shielding of the outgoing cable. Do not connect the shielding to the device or to anything else. At the last device on the daisy chain, do not connect the shielding; leave it unconnected.

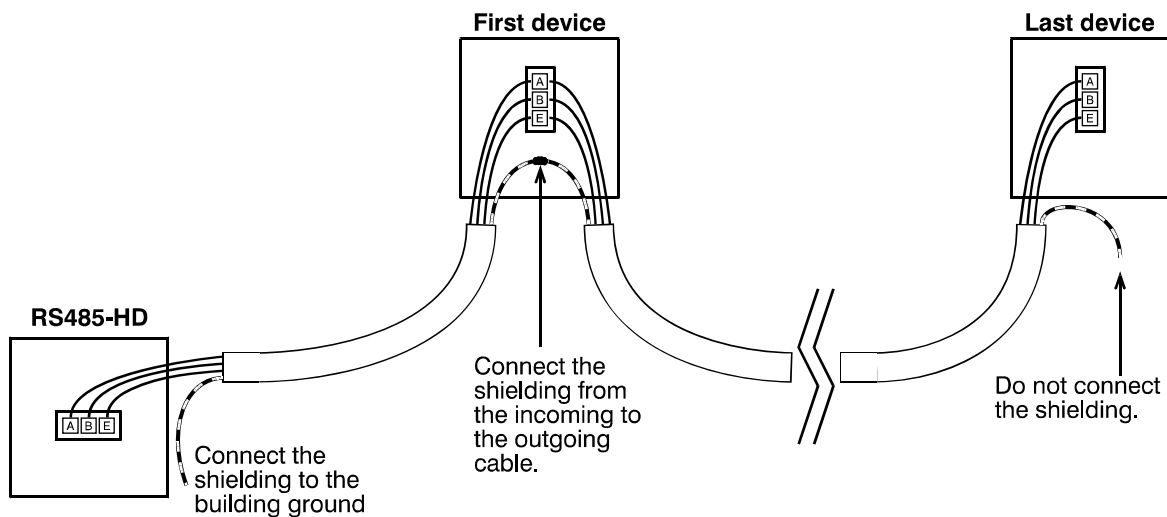

### Connecting the communication wiring

Follow the instructions below to connect the communication wiring.

#### To connect the communication wiring

1. Connect all the devices in series. For example, **A** on the RS-485-HD to **A** on the first device, to **A** on the second device, and so on. Use the wires specified in the table on page 2 and follow the guidelines on page 3.
2. If the device uses termination resistors to terminate the communication channel, remove the termination resistors from each device, *except for the last one on the communication channel*. The last device *must* have the termination resistors in place. For the location of the termination resistors, see the installation guide for the device.

If the device uses a jumper/shunt to terminate the communication channel, position the jumper in the enable/terminate position. The default position from factory is "enable".

## Connecting the RS-485-HD to the computer

After connecting the communication wiring to all the devices, connect the RS-485-HD to the computer.

### To connect the RS-485-HD to the computer

1. Plug the communication connector into the communication socket on the RS-485-HD.
2. Connect the square end of the USB cable to the RS-485-HD and the rectangular end directly to one of your computer's USB ports.

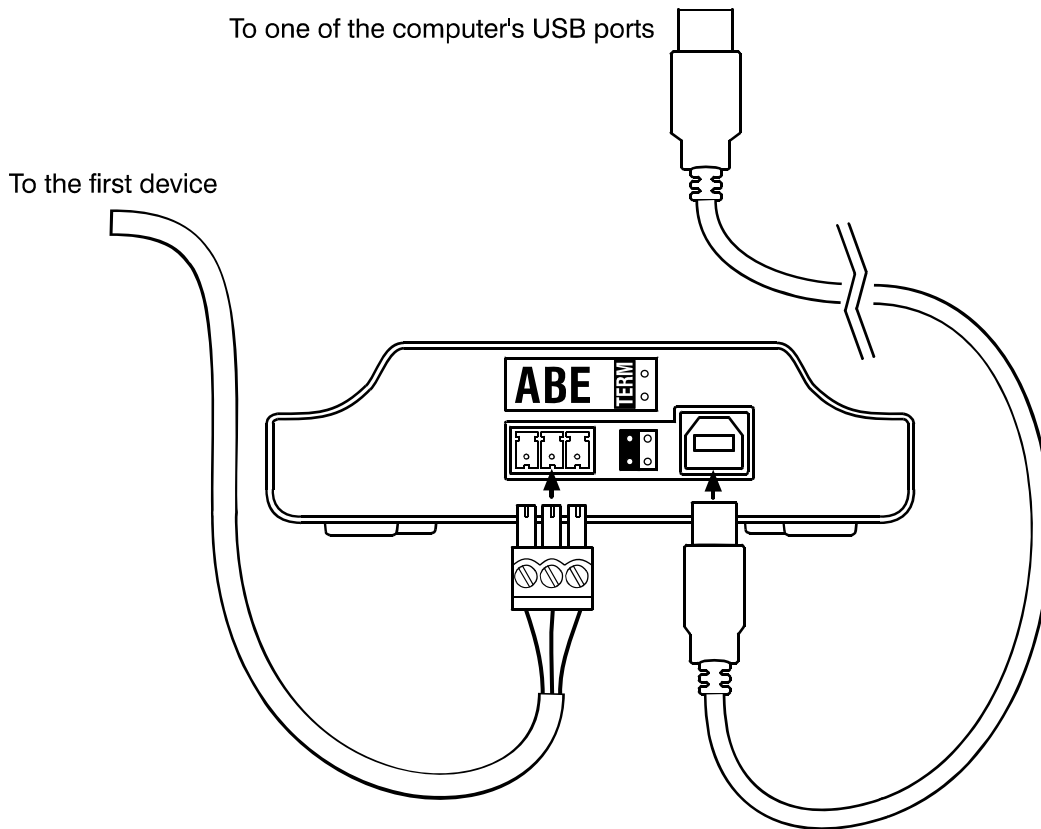

Because of the RS485 power requirements, if you are using a USB hub, it must be one that has an external power supply, *not one powered from the computer's USB port.*

If this is the first time you have connected the RS485-HD to the computer, your operating system (Windows XP or Windows Vista) will tell you that it has detected new hardware and ask to install the drivers. Read the next section before installing the drivers.

## Installing the software drivers

The first time you connect the RS485-HD, your operating system will ask you for software drivers. Software drivers tell the computer how to operate the RS485-HD.

There are two drivers to install: one called **USB Serial Converter**, the other called **USB Serial Port**. The drivers are on the CD that came with the RS485-HD package.

After both drivers have been successfully installed, the power LED on the RS485-HD should light up green.

### To install the software drivers

1. Insert the CD into your computer's CD/DVD-ROM drive.
2. Follow the instructions on the screen to install the driver for the USB Serial Converter from the CD.
3. Repeat step 2 for the USB Serial Port driver.

---

#### Phason Inc.

2 Terracon Place

Winnipeg, Manitoba, Canada

R2J 4G7

Phone: 204-233-1400

Fax: 204-233-3252

E-mail: [support@phason.ca](mailto:support@phason.ca)

Web site: [www.phason.ca](http://www.phason.ca)