

Manure Level Sensor installation guide

The Manure Level Sensor works with OMNI-Manure to measure and monitor manure levels in a manure reservoir. The Manure Level Sensor uses ultrasonic technology to accurately measure the levels. The sensor emits ultrasonic pulses that are reflected by the manure. The sensor measures the time the pulses take to reflect back to the sensor and then sends the data to the OMNI-Manure software.

What you need to know before installing the MLS

The Manure Level Sensor requires careful installation for proper long-term operation. Carefully read and follow *all* the instructions in the order they are listed. If you do not follow the instructions and install the Manure Level Sensor properly, the Manure Level Sensor might not operate properly.

- ◆ Use conduit to protect all communication and power cables.
- ◆ Make sure the communication and sensor cables do not become pinched or bent.
- ◆ When selecting a location for the sensor and control units, select a location where they will not be damaged when the tank is filled or pumped.



DO NOT open the sensor unit. This will damage the seal and void the warranty.

Mount the control on a sheltered, vertical surface, with the electrical knockouts facing down.

Use a screwdriver to tighten the screws in the enclosure. Do not use a drill or over tighten the screws; this can crack the enclosure and ruin the watertight seal.

Use the electrical knockouts for bringing wires or cables into or out of the enclosure. Use watertight strain reliefs or conduit connectors at all cable-entry points.

Do not make additional holes in the enclosure; this can damage the watertight seal or control components and void the warranty.

Routing data wires

Routing data wires in the same conduit as, or beside AC power cables, can cause electrical interference, erratic readings, and/or improper control. Data wires include **all** of the following:

- ◆ Temperature probe and humidity sensor cables
- ◆ Actuator feedback (potentiometer) wires
- ◆ Data communication wires, including RS-232/RS-485
- ◆ Any cable or wire that does not provide AC power

Guidelines for routing data wires

- ◆ Do not run the wires in the same conduit as AC power cables.
- ◆ Do not run the wires beside AC power cables or near electrical equipment.
- ◆ When crossing other cables or power lines, cross them at a 90-degree angle.

If in doubt, **do not run any wire or cable that is not an AC-power wire** inside the same conduit or beside other AC-power wires.

Parts list

The Manure Level Sensor (MLS) hardware consists of the control unit, sensor unit, and the mounting brackets and hardware. The sensor unit has a cable attached to it that connects to the control unit.

The following parts are included with your Manure Level Sensor

- | | |
|-------------------------------|-----------------------------|
| ◆ Control unit | ◆ 2-inch masonry screws (8) |
| ◆ Sensor unit | ◆ Mounting bracket (base) |
| ◆ Installation guide | ◆ Mounting bracket (top) |
| ◆ 5/8-inch strain relief | ◆ 1-inch mounting bolts (7) |
| ◆ 5/8-inch strain relief nut | ◆ Nuts (7) |
| ◆ 3/16-inch masonry drill bit | ◆ U-bolt assemblies (2) |

In addition to the parts included with the Manure Level Sensor, you need to provide the following items.

Item	Notes
Phason Regulated Power Supply	
Power cable	<ul style="list-style-type: none"> ◇ Weather resistant, 20 AWG or larger ◇ Enough to go from the power supply to the control unit ◇ Longer distances require larger wire
Communication cable	<ul style="list-style-type: none"> ◇ Unshielded twisted pair (UTP), category 3 or higher (category 5 recommended) ◇ Enough to go from the OMNI-Server or Power Block to the control unit
Conduit	<ul style="list-style-type: none"> ◇ Metal, 3/4-inch diameter ◇ Minimum 5 feet, maximum 6 feet
Strain reliefs or conduit connectors	◇ Use watertight strain reliefs or conduit connectors at all cable entry points

Control unit layout

Incoming power terminal block

Connect the incoming DC power to this terminal block.

Communication socket

Plug the communication connector into this socket.

Communication cable

Run the communication cable through this knockout.

Power cable

Run the incoming power cable through this knockout.

Sensor cable

Run the sensor cable through this knockout.

Sensor terminal blocks

Connect the sensor unit wires to these terminal blocks.

Termination resistors

If there are any devices on this communication channel after this Manure Level Sensor, then use wire cutters to remove *only these two* resistors.

Address label

This is the Manure Level Sensor's address on the OMNI-4000 system. Write down this address, the person installing the software will need it.

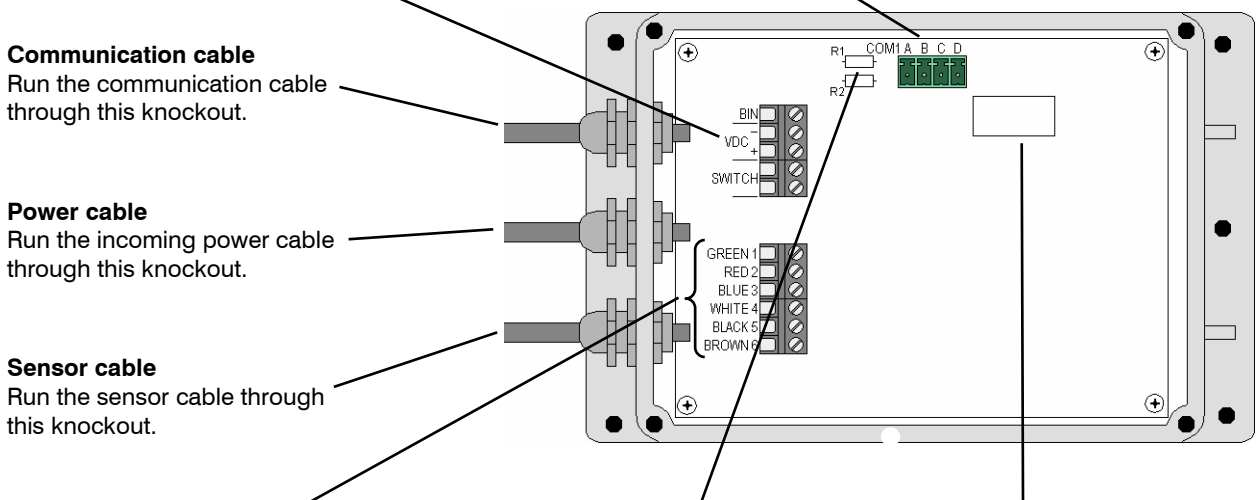

Electrical ratings

- ◆ 10 to 14 VDC
- ◆ 125 mA

Installing the Manure Level Sensor

Complete the following steps in the order they are listed.

Assemble the bracket

1. Insert three of the mounting screws through the center row of holes in the bracket base.
2. Place the bracket top over the screws and then fasten it to the bottom using three of the nuts.

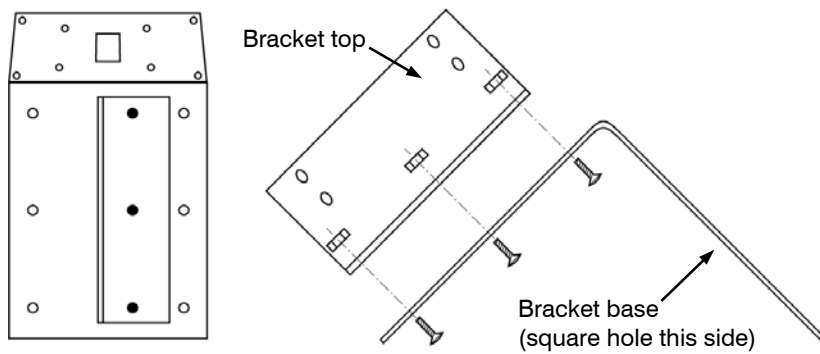

Mark and drill the mounting holes

1. Place the bracket on the edge of the tank.
2. Mark the four black holes for the top using a marker or punch. Be careful not to move the bracket while you are marking the holes.
3. Mark the four black holes for the side.
4. Make sure all the holes line up and then remove the bracket.
5. Drill the holes using the masonry bit.

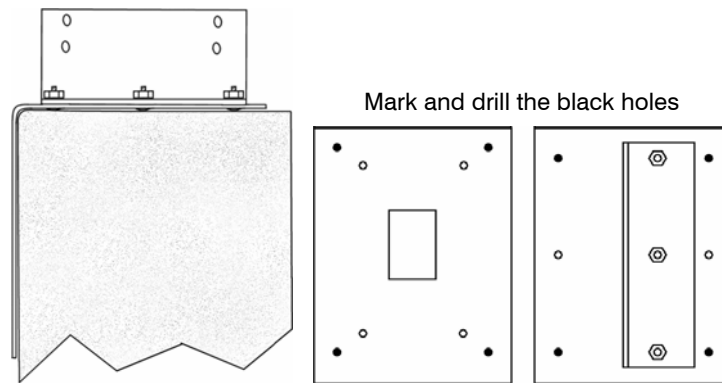

Fasten the control unit to the bracket

1. Insert the remaining four mounting screws through the four inside holes in the bracket base.
2. Place the control unit over the screws with the electrical knockouts facing down.
3. Fasten the control unit to the base using the remaining nuts.

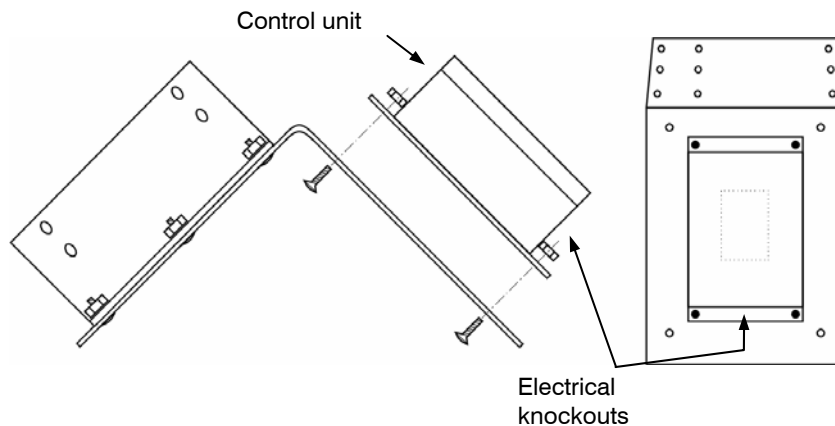

Fasten the bracket to the tank

1. Place the bracket over the drilled holes. Make sure all the holes line up.
2. Fasten the bracket to the tank using the masonry screws.

Fasten the sensor to the bracket

1. Insert the U-bolts through the holes in the bracket and then attach the washers and nuts. Do not tighten the nuts at this time.
2. Run the sensor cable through a five to six foot piece of $\frac{3}{4}$ -inch conduit.
3. Fasten the conduit to the conduit connector.
4. Insert the conduit through the U-bolts and then align the sensor so that the screen is pointing down.
5. Tighten the nuts on the U-bolts.

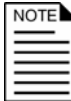

The sensor screen must be pointing down at a 90-degree angle or it will not provide accurate readings.

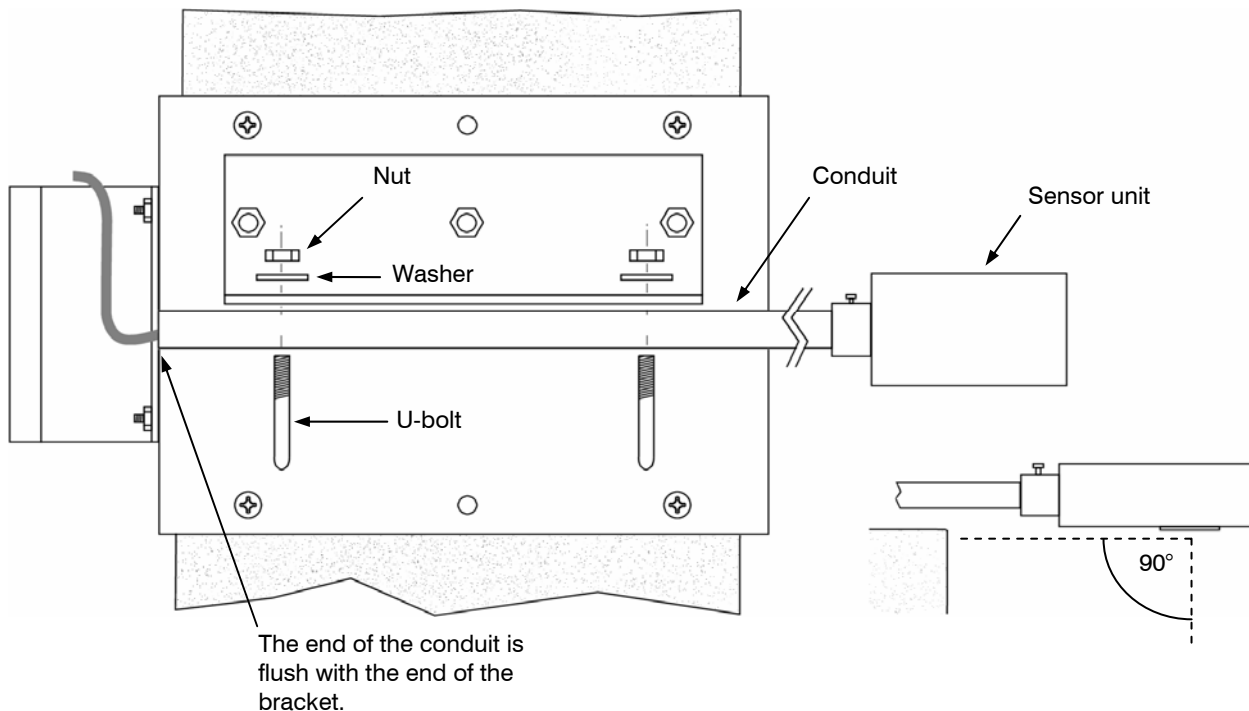

Connect the sensor cable to the control unit

1. Remove the cover from the control unit.
2. Run the cable from the conduit down to the control unit.
3. Insert the cable through the strain relief in the control unit and then tighten the strain relief nut.
4. Connect the sensor wires to their terminal blocks according their color (for example, green sensor wire to **GREEN** terminal block). See the drawing on page 3 for locations.

NOTE

DO NOT cut, splice, or add onto the sensor cable.

Connecting the communication wiring

There are three possible connector types on Phason devices. The four-positions, **A B C D**, are common to all models. Newer models have five positions and include **E** for common reference wiring. The six-position connectors that include position **1** are included on the RS-485A and OMNI Alarm Manager (OAM) only.

Using consistent wiring helps eliminate communication connection errors and makes troubleshooting much easier.

Use the wire colors in the following table when connecting all devices to the communication system.

Four-pin connector

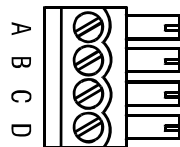

Five-pin connector

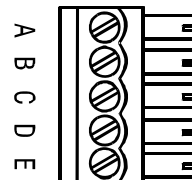

Six-pin connector

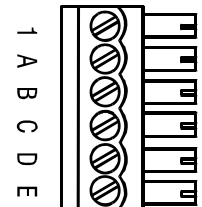

Wire function	RS-485A wire colors	First device	All remaining devices
1 alarm signal ^①	1 white/green	1 white/green	1 white/green
A communication	A blue	A blue	A blue
B communication	B white/blue	B white/blue	B white/blue
C communication	C orange	C orange	C orange
D communication	D white/orange	D white/orange	D white/orange
E common reference ^②	E green	E green	E green

① For OMNI systems with an OMNI Alarm Manager only

② Not available on all models

Common mistakes in communication wiring

- ◆ **Not using the correct type of communication cable**—the communication cable must be unshielded twisted pair cable (UTP), category 3 or category 5. Phason does not recommend other types of wire.
- ◆ **Not continuing the communication wiring properly**—all the devices on the communication channel must be connected in series and the wire must be continued properly from one device to the next. When continuing the communication wiring from one device to the next, the wires must be connected as shown below.

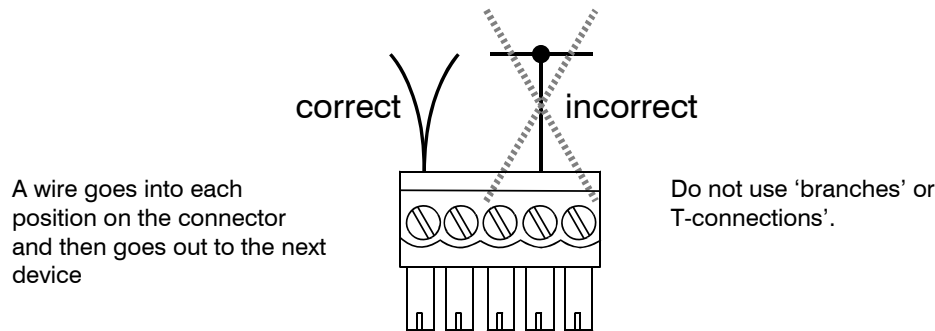

- ◆ **Not terminating the last device on the communication channel**—on all systems, the last device on the communication channel must have the termination resistors in place or a termination module installed.

The termination resistors are located on the circuit board of all networkable devices, except the Supra (the Supra uses a Termination Module). You must remove the termination resistors from all devices, except the last one on the communication channel.

The termination resistors on OMNI Power Blocks are in sockets on the Micro Board and can be removed and replaced if necessary. Termination resistors on all other models must be removed using wire cutters. For more information about the location of termination resistors, see the installation guide for your specific product.

If you remove the termination resistors from the last device by mistake, you will have to install a Termination Module on that device. The Termination Module connects to the communication socket on the last device. For information about Termination Modules, contact your dealer or Phason Customer Support.

- ◆ **Running the communication cable in the same conduit as, or beside AC power cables**—routing communication cable in the same conduit as, or beside AC power cables, can cause electrical interference and communication failures. Follow the guidelines below when routing communication cable.
 - ◆ Do not run the cable in the same conduit as AC power cables.
 - ◆ Do not run the cable beside AC power cables or near electrical equipment.
 - ◆ When crossing other cables or power lines, cross them at a 90-degree angle.

Connecting the communication cable to the MLS



If you are using conduit for the communication and power cables, run all the cables in a single conduit and into the enclosure through the middle electrical knockout.

If you are using strain reliefs, remove the left electrical knockout (or drill an appropriately-sized hole in the knockout) and then insert the communication cable into the enclosure through a watertight strain relief. See the diagram on page 3 for the location.

1. Insert the communication cable through the strain relief or conduit connector.
2. Remove the communication connector from the socket.
3. Connect the communication wires.
4. If the MLS is not the last device on the communication channel, use side cutters to remove the termination resistors from the circuit board. See the diagram on page 3 for the location.

Connect the control unit to the power supply

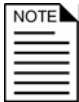

If you are using strain reliefs, use the 1/2-inch hole in the middle electrical knockout (or drill an appropriately sized hole in the knockout) and insert the power cable into the enclosure through a watertight strain relief. See the diagram on page 3 for the location.

1. Connect the negative DC power wire to the **VDC-** terminal.
2. Connect the positive DC power wire to the **VDC+** terminal.

Fasten the cover to the control unit

1. Check to make sure you have connected all the wires to their proper locations.
2. Write down the Manure Level Sensor address (see the diagram on page 3 for the location), the person installing the software will need this information.
3. Fasten the cover to the control unit.

Limited warranty

This warranty applies only to the Manure Level Sensor (MLS). If you need warranty service, return the product and original proof of purchase to your dealer.

Phason Inc. (Phason) warrants this product subject to the following terms and conditions.

This warranty is valid only to the original purchaser of the MLS, for two years from the manufacturing date. The manufacturing date is stated in the first eight digits of the serial number in the form year-month-day.

Phason hereby warrants that should the MLS fail because of improper workmanship, Phason will repair the MLS, effecting all necessary parts replacements without charge for either parts or labor.

Conditions

- ◆ Installation must be done according to our enclosed installation instructions.
- ◆ The MLS must not have been previously altered, modified, or repaired by anyone other than Phason.
- ◆ The MLS must not have been involved in an accident, misused, abused, or operated or installed contrary to the instructions in our user and/or installation manuals. Phason's opinion about these items is final.
- ◆ The person requesting warranty service must be the original purchaser of the MLS, and provide proof of purchase upon request.
- ◆ All transportation charges for products submitted for warranty must be paid by the purchaser.

Except to the extent prohibited by applicable law, no other warranties, whether expressed or implied, including warranties of merchantability and fitness for a particular purpose, shall apply to the MLS. Any implied warranties are excluded.

Phason is not liable for consequential damages caused by the MLS.

Phason does not assume or authorize any representatives, or other people, to assume any obligations or liabilities, other than those specifically stated in this warranty.

Phason reserves the right to improve or alter the MLS without notice.

Phason Inc.
2 Terracon Place
Winnipeg, Manitoba, Canada
R2J 4G7

Phone: 204-233-1400
Fax: 204-233-3252

E-mail: support@phason.ca
Web site: www.phason.ca