

PSU-20 Single-Phase Slave installation guide

The Single-Phase Slave (model PSU-20) is an affordable way to increase the capacity of your Phason “slave-capable” control system. Installation is simple and there is no additional configuration required; all slave units follow the programs and settings of the master control.

The following Phason controls are “slave-capable”:

- ◆ Programmable Lighting Control (PLC-1 and PLC-2)
- ◆ Supra

The Single-Phase Slave must be on the same phase as the master control. If you are using a Programmable Lighting Control, the more advanced Three-Phase Slave (PLC-2SDC) does not require all units to be on the same phase, allowing you to distribute the load across all three phases.

What you need to know before installing your Single-Phase Slave

Electrical ratings

- ◆ Input: 120 VAC, 50/60 Hz
- ◆ Variable AC output: 2300 W at 120 VAC
20 A at 120 VAC, general-purpose (resistive)
7 FLA at 120/230 VAC, PSC motor
1/2 HP at 120 VAC, 1 HP at 230 VAC, PSC motor

Parts included

The following are included with the PSU-20:

- ◆ PSU-20 Single-Phase Slave
- ◆ Single-Phase Slave Cable
- ◆ Four mounting screws
- ◆ PSU-20 installation guide

In addition to the parts included with the PSU-20, you need to provide an external disconnect switch for the variable AC stage.

Precautions, guidelines, and warnings

A qualified electrician must install the PSU-20.

Before installing or servicing the PSU-20, switch OFF the power at the source.

Install the PSU-20 and all equipment connected to it according to local electrical codes.

Install an external disconnect switch in series with the variable AC stage.

Mount the enclosures on a sheltered, vertical surface, with the electrical knockouts facing down.

Use a screwdriver to tighten the screws in the enclosures. Do not use a drill or over tighten the screws; this can crack the enclosures and ruin the watertight seal.

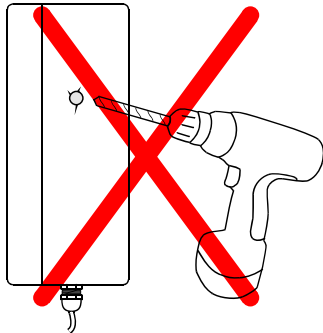
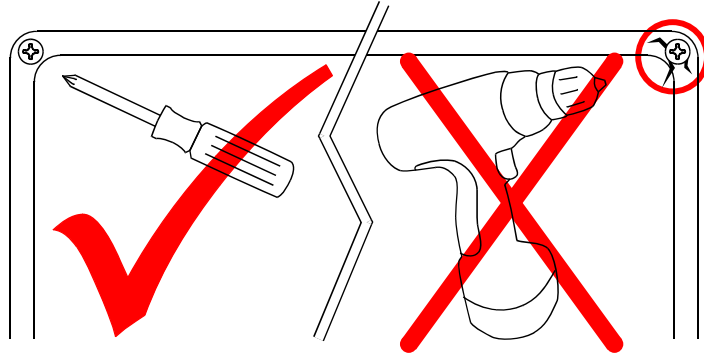

Use the electrical knockouts for bringing wires or cables into or out of the enclosures. Use watertight strain reliefs or conduit connectors at all cable-entry points.

Do not make additional holes in the enclosures; this can damage the watertight seal or control components and void the warranty.

Routing data wires

Routing data wires in the same conduit as, or beside AC power cables, can cause electrical interference, erratic readings, and/or improper control. Data wires include **all** of the following:

- ◆ DC-signal wires, *including the slave cable*
- ◆ Temperature probe and humidity sensor cables
- ◆ Data communication wires, including RS-232/RS-485
- ◆ Any cable or wire that does not provide AC power

Guidelines for routing data wires

- ◆ Do not run the wires in the same conduit as AC power cables.
- ◆ Do not run the wires beside AC power cables or near electrical equipment.
- ◆ When crossing other cables or power lines, cross them at a 90-degree angle.

If in doubt, **do not run any wire or cable that is not an AC-power wire** inside the same conduit or beside other AC-power wires.

Installing the Single-Phase Slave

Follow all steps in the order they are listed.

Mounting the slave unit

1. Select a location for the unit. Make sure the slave cable can reach from the master control to the slave unit. Longer slave cables are not available.
2. Remove the screws from the front cover and then gently lift it off.
3. Mount the enclosure to a wall using the four screws provided with the control. Insert the screws into the large holes in each corner of the box and then tighten.

Connecting the slave units to the master control

Follow the instructions for the type of master control you are using.

Supra

You can connect up to six Single-Phase Slaves to one Supra. For sites with three-phase power, it is preferable to use three Supras so loads are distributed evenly across all three phases.

On the Supra, there are two connectors labeled **VR3** and **VR4**. The connectors are for connecting slave units to variable stages 3 and 4 respectively.

When a slave unit is connected to variable stage 3 (**VR3**), it follows the Supra's programmed settings for variable stage 3. When a slave unit is connected to variable stage 4, it follows the settings for that stage. For more information, see the **Supra user manual**.

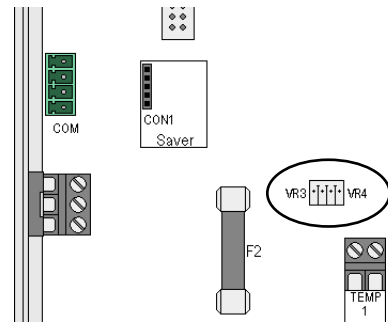

When connecting a single slave unit, connect the slave cable from **VR3** or **VR4** to **SLAVE1 B**. When connecting additional slaves, connect the cable from **SLAVE1 A** to **SLAVE1 B**.

The following example shows the slave cable connections for connecting two slaves to variable stage 3 and two slaves to variable stage 4.

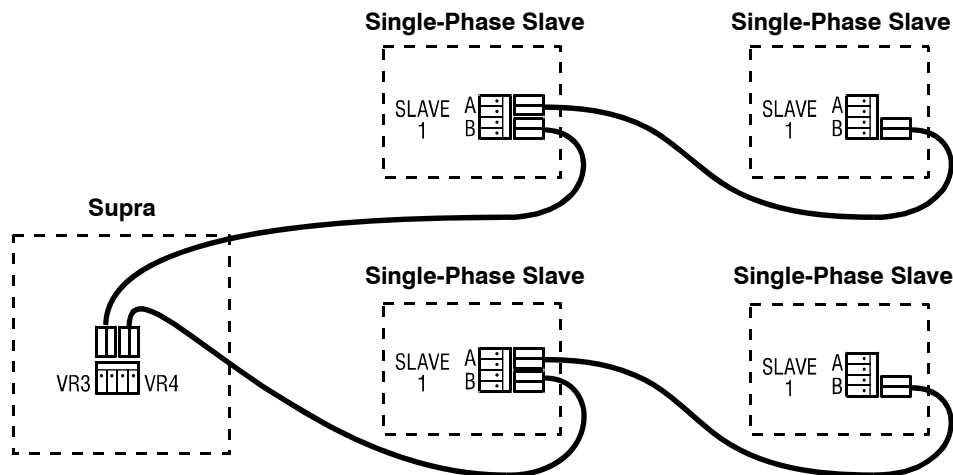

Programmable Lighting Control (PLC-1 and PLC-2)

You can connect up to six Single-Phase Slaves to one Programmable Lighting Control.

On the PLCs, there are two connectors labeled **SLAVE1** and **SLAVE2**. The connectors are for connecting slave units to variable AC stages 1 and 2 respectively.

When a slave unit is connected to variable stage 1 (**SLAVE1**), it follows the PLC's settings for the program group to which variable stage 1 is assigned. When a slave unit is connected to variable stage 2, it follows the settings for the program group to which that stage is assigned. For more information, see the **PLC user manual**.

When connecting a single slave unit, connect the slave cable from **SLAVE1 A** or **SLAVE2 A** to **SLAVE1 B**. When connecting additional slaves, connect the cable from **SLAVE1 A** to **SLAVE1 B**.

The following example shows the slave cable connections for connecting two slaves to variable stage 1 and two slaves to variable stage 2.

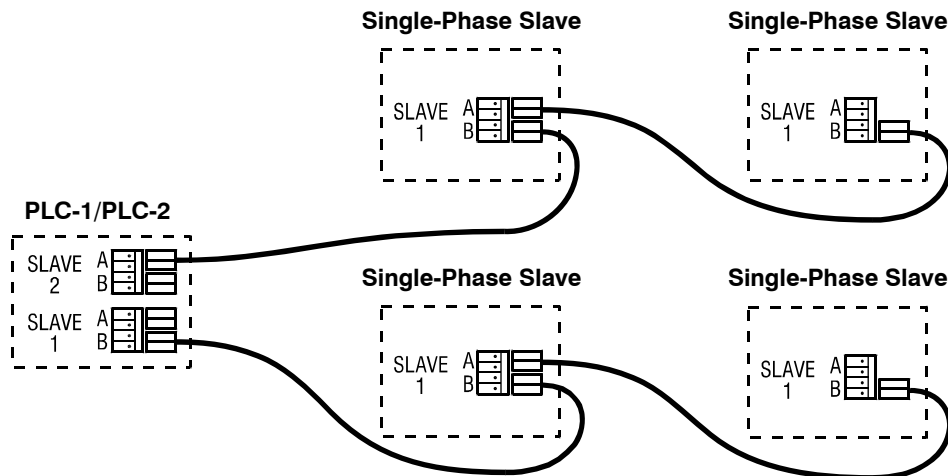

NOTE

You cannot connect slaves to variable stages 1 and 2 on Supras.

Connecting the load and incoming power

The PSU-20's variable AC output is for controlling loads such as variable-speed fans, heat lamps, or incandescent lights.

Connect the equipment and disconnect switches as shown below.

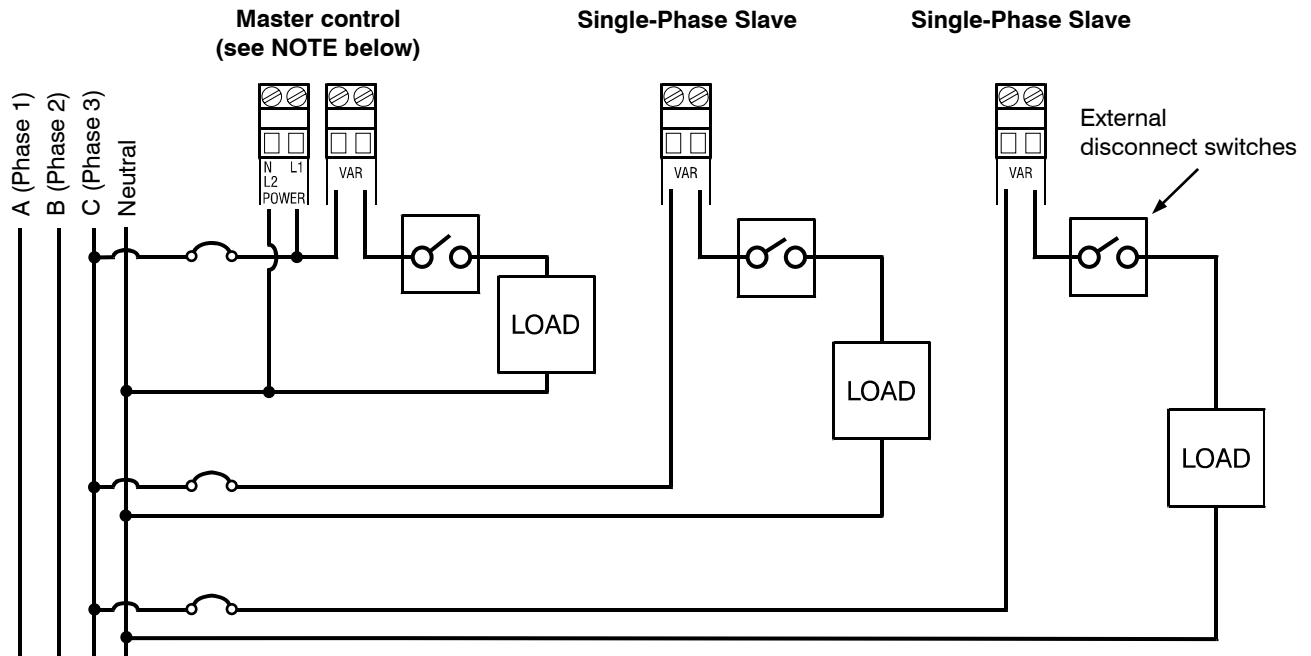

NOTE If you have three-phase power and are using Single-Phase Slaves, you must connect the equipment to the same phase as the master control. The master control in the above diagram shows the terminals for a Programmable Lighting Control. Your master control might have different terminals. For more information, see your control's installation guide.

Finishing the installation

1. Make sure all the wires are properly connected to the correct terminals.
2. Switch on the power to your control system and then make sure all your equipment functions properly.
3. Place the cover on the unit.
4. Insert the four screws into the cover and then tighten them.



Do not over tighten the screws. Avoid using power screwdrivers or drills.

Servicing and maintaining your Single-Phase Slave

Servicing and maintaining your Single-Phase Slave will extend the life of the control and your equipment.



Before installing or servicing your control, switch OFF the power at the source.



DO NOT direct a high-pressure washer at the control.

Do not use harsh or abrasive cleaners or rub the surface of the control with your bare hands.

Cleaning

- ◆ Use caution when washing the room with a high-pressure washer.
- ◆ To clean the surface of the control, wipe it with a damp cloth.

Moisture

Moisture will not cause problems with the control if you take proper care during installation.

1. After the first two weeks of operation, remove the cover from the unit and check inside for moisture. Be sure to turn off the power to the control before opening the cover.
2. If there is moisture present, wipe it out with a dry cloth and check the cable entry points and rubber gasket for proper sealing.
3. If the cable connectors are not sealing, apply RTV or Silicon II (non acetic acid) sealant around the cable.

Some silicone sealants release acetic acid while curing. This can cause corrosion and damage the control. Let the silicone cure completely (one to three days) with the cover open and ensure no moisture enters the control. Failure to do this might damage the control and void the warranty.

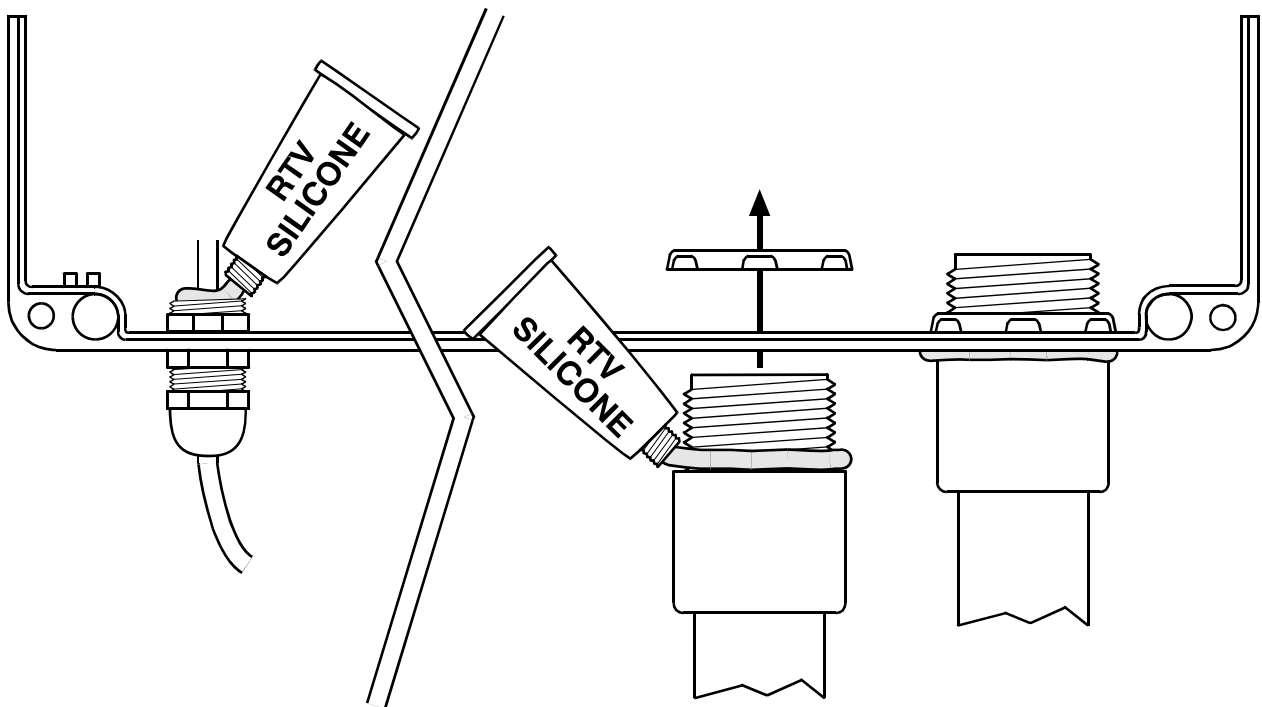

4. Open and inspect the control after two weeks to verify it is sealing properly.



Open and inspect the control for moisture once a year. Proper care and maintenance will extend the life of the control.

Phason Inc.

2 Terracon Place
Winnipeg, Manitoba Canada
R2J 4G7

Phone: 204-233-1400
Fax: 204-233-3252

E-mail: support@phason.ca
Web site: www.phason.ca