

Power and phase loss detection—new risk management and insurance solutions

With the recent release of the Phase Detection Sensor (PDS-1) and the Power Loss Sensor (PLS-1), Phason is pleased to offer a 'Risk management and insurance solution' to producers.

What is Phason's 'risk management and insurance solution?'

Phason's Phase Detection Sensor (PDS-1) works with OMNI-4000's Local Environment Monitor (LEM) and OMNI-Site Watcher to continuously monitor three-phase power. The Power Loss Sensor (PLS-1) works with the LEM and OMNI-Site Watcher to continuously monitor single-phase, 120 VAC power.

OMNI-Site Watcher and the Local Environment Monitors already provide the ability to monitor such critical conditions as temperatures, humidity, pH, and more. The added option of power and/or phase-loss detection makes the package even more attractive to producers. When combined with OMNI-Alert, the package becomes an integral part of a 'Risk management and livestock insurance strategy'.

"Insurers are fast developing requirements for comprehensive alarm and monitoring systems in confined swine facilities. Because of the inherent high risk, barns must now have monitoring systems that respond not only to complete (whole site) power interruptions, but must also respond to a partial power failure.

Insurers will likely want to review the pre-loss data that a good system will be able to monitor and record. Logging temperature and power performance is a fundamental part of an effective loss-prevention program.

Because comprehensive systems allow owners to do effective risk management, insurers will respond with meaningful premium credit considerations. These discounts are worthwhile and make a significant contribution to respective installation costs.

Lakeview Insurance Brokers Ltd. is actively working with all our clients to encourage them to install systems that provide both alarm and monitoring functions. Many insurers will no longer offer any form of suffocation coverage without them."

Sid B. Reimer,

Vice President

Lakeview Insurance Brokers Ltd.

Winnipeg, Manitoba

An OMNI-4000 system containing the above components meets the following general livestock insurance requirements:

- ◆ Must have a permanent connection to an automatic alarm system
- ◆ Must function 24 hours a day
- ◆ Must be capable of detecting and logging power interruptions for the whole site, as well as in each room containing 'insured animals'
- ◆ Must be capable of detecting and logging critical temperatures (high and low) in each room containing 'insured animals'
- ◆ Must be capable of monitoring and logging backup generator test cycles
- ◆ Must be capable of automatically alerting the persons designated to respond to the above alarms

How does phase-loss or power failure monitoring work?

Phason's Phase Detection Sensor (PDS-1) works with the Local Environment Monitor and OMNI-Site Watcher to continuously monitor three-phase power. The PDS-1's phase-monitoring relay has adjustable voltage (200 to 480 VAC), unbalance trigger (2 to 10 % variation), and trip delay (0.25 to 30 seconds) settings. When the voltage on a phase varies by more than the unbalance trigger percentage and for longer than the trip delay, the relay opens, signaling the LEM.

Phason's Power Loss Sensor (PLS-1) works with the LEM and OMNI-Site Watcher to continuously monitor single-phase, 120 VAC power. The PLS-1's voltage-sensing relay has an adjustable dropout voltage of 90 to 103 V. When the voltage drops below the dropout value, the relay opens, signaling the LEM.

If the power stays off longer than the fault duration, which you set in the OMNI-Site Watcher software, the LEM signals the OMNI-4000 software that there is an alarm condition. If the alarm class is set to active in OMNI-Alert, the system dials the contacts on its call list and notifies them about the condition.

How does critical temperature monitoring work?

Critical temperatures are temperatures that are out of range (too high or too low) and threaten the health or life of insured animals. Monitoring critical temperatures works very similar to power/phase-loss monitoring.

The Local Environment Monitor comes with a temperature probe that you can use for monitoring temperatures in a critical area. In the OMNI-Site Watcher software, you set the upper and lower temperature limits. When the temperature rises above the upper limit, or falls below the lower limit, the LEM indicates a fault condition.

If the temperature stays out of range for longer than the fault duration, the LEM signals the software that there is an alarm condition. If the alarm class is set to active in OMNI-Alert, the system dials the contacts on its call list and notifies them about the condition. You can connect up to four temperature probes to a LEM.

How does generator test cycle monitoring work?

The High Temperature Probe (HTP) is designed for monitoring temperatures ranging from 86 to 302°F (30 to 150°C). The HTP connects to the Local Environment Monitor and is especially useful for monitoring generator temperatures.

By placing a probe near the exhaust outlet or mounting it on the casing of a generator, you can determine when and for how long a generator has been running. Using the OMNI-Site Watcher charts or reports, you can provide a record of generator temperatures and run times—often a requirement for insurance purposes.

As with critical temperature monitoring, you can set upper and lower temperature limits. When the temperature goes out of range the LEM indicates a fault condition.

If the temperature stays out of range for longer than the fault duration, the LEM signals the software that there is an alarm condition. If the alarm class is set to active in OMNI-Alert, the system dials the contacts on its call list and notifies them about the condition.

What components are required?

Phason’s complete OMNI-4000 risk management and insurance solution requires the following:

Computer and other miscellaneous devices	
Personal computer	Required to run OMNI software
OMNI Modem (MDM1)	Required for OMNI-Alert
Dedicated phone line	Required for OMNI-Alert
Uninterruptible power supply	Required for backup power to the computer
OMNI-4000 software	
OMNI-Site Watcher software module	Monitors critical conditions
OMNI-Alert software module	Notifies personnel about alarm conditions
OMNI-4000 communication devices	
OMNI Server	
OMNI-Alarm Manager (OAM)	
RS-485A Converter	
OMNI-4000 devices and sensors	
Local Environment Monitor (LEM)	Monitors power fail circuits and other sensors*
Power Loss Sensor (PLS-1)	For 120 VAC, single-phase power loss
<i>or</i>	<i>or</i>
Phase Detection Sensor (PDS-1)	For phase loss or three-phase-power loss
Temperature probes	For monitoring critical temperatures
High Temperature Probe (HTP)	For monitoring backup generator temperatures
13.6 VDC Regulated Power Supply (RPS)	Powers the LEMs
RPS Battery Cable	Required for backup power to the LEMs
12-V gel cell battery	Required for backup power to the LEMs
*In addition, there are many other optional sensors you can connect to a Local Environment Monitor, such as humidity sensors, pressure switches, and door contact switches.	

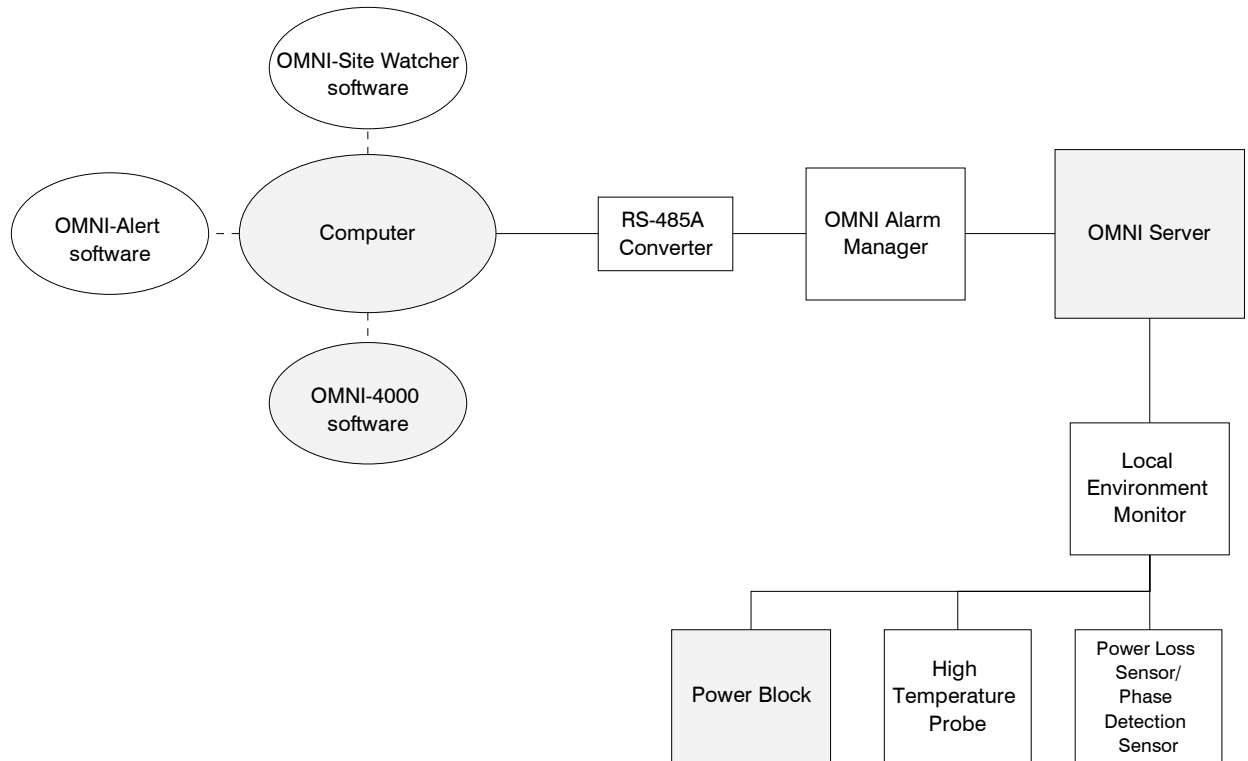

Detailed product information

OMNI-Alert

Because you can't be everywhere at once

Problems at a site can cause damage to buildings and equipment, the death of animals, and loss of profits. OMNI-Alert provides peace of mind by helping ensure that if there is a problem at your site, the right people will be notified of the problem.

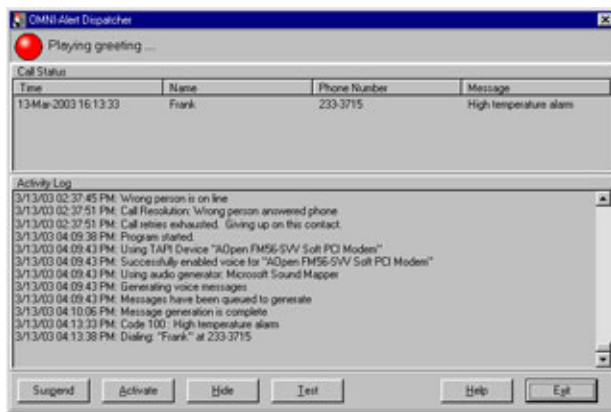

OMNI-Alert uses a voice modem and text-to-speech technology to convert OMNI-4000 alarm messages to speech over phone lines. The system monitors all OMNI-4000 modules at your site. If a module reports an alarm condition, OMNI-Alert calls your contacts and notifies them of the condition.

The OMNI-Alert Dispatcher displays information about OMNI-Alert, including status, recent activity, and calls to be processed.

When combined with OMNI-Site Watcher, you have a complete site monitoring system. OMNI-Alert—a valuable part of your OMNI-4000 site.

Features

- ◆ Text-to-speech voice technology
- ◆ PIN security system
- ◆ Customizable calling options, including:
 - ◆ Alarm greeting
 - ◆ No answer time-out
 - ◆ No answer retries
 - ◆ Acknowledge time-out
 - ◆ Acknowledge retries
 - ◆ Number of message replays
- ◆ Configurable active and inactive alarm class schedules and contact schedules
- ◆ Configurable calling list and calling priority
- ◆ Easy-to-create HTML reports, including:
 - ◆ Alarm Log
 - ◆ OMNI-Alert Activity Log
 - ◆ OMNI-Alert Configuration Report

Other requirements and information

- ◆ OMNI-4000 software
- ◆ MDM1 (OMNI Modem)
- ◆ Dedicated phone line

OMNI-Site Watcher

Monitor critical conditions in every room at your site

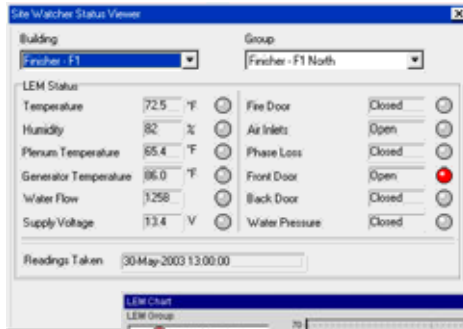

OMNI-Site Watcher works with the Local Environment Monitor (LEM) to monitor critical conditions at your site. Using multiple Local Environment Monitors, you can monitor conditions in every room or zone at your site.

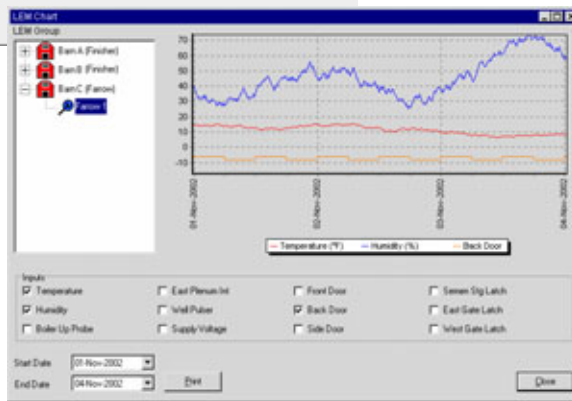

OMNI-Site Watcher's status display and easy-to-use charts and reports display information at a glance and allow you to "keep an eye" on your site. When combined with OMNI-Alert, you have a complete site monitoring system.

As with all OMNI-4000 software modules, you can export information to third-party software such as databases, spreadsheet programs, or reporting packages.

Features

- ◆ Twelve programmable alarms with notification and logging
- ◆ Near real-time information collection and display
- ◆ Information at a glance
- ◆ Easy-to-read status displays
- ◆ Easy-to-use charting and reporting tools
- ◆ OMNI-Alert compatibility

Local Environment Monitor (LEM)

Designed to continuously monitor critical conditions and variables not monitored by other OMNI-4000 modules

The Local Environment Monitor works with OMNI-Site Watcher to continuously monitor critical conditions at your site and notify OMNI-4000 of any alarm conditions. Using multiple Local Environment Monitors, you can monitor conditions in every room or zone at your site.

The LEM automatically monitors its supply voltage and comes with 11 monitoring inputs: 6 digital, 4 analog, and 1 pulse counter. These inputs allow you to customize your monitoring system to monitor virtually anything you want.



Input type	Number	Uses
Analog inputs	4	'Variable condition' monitoring such as temperature, humidity, or pH
Digital inputs	6	'On/off' or 'open/closed' monitoring such as door contacts, pressure switches, or power failure
Pulse counter	1	'Count monitoring' such as electrical pulses from water meters

The Local Environment Monitor comes with a 30-foot temperature probe for monitoring outdoor or ambient temperatures. Additional sensors and probes are available.

Features

- ◆ 11 customizable monitoring inputs
- ◆ Alarm relay
- ◆ Easy installation
- ◆ Temperature probe with 30-foot cable
- ◆ Rugged enclosure (corrosion resistant, water resistant, and fire retardant)
- ◆ Two-year limited warranty

Electrical ratings

- ◆ Input:
 - ◆ 10 to 14 VDC
 - ◆ 100 mA
- ◆ Alarm relay:
 - ◆ 0.2 A at 230 VAC
 - ◆ 0.4 A at 24 VAC
 - ◆ 2.0 A at 30 VDC

NOTE: One Phason Regulated Power Supply (RPS) can supply power for up to 11 LEMs.

Power Loss Sensor (PLS-1)

Reliably detect 120 VAC, single-phase power loss

Phason's Power Loss Sensor (PLS-1) works with the Local Environment Monitor (LEM) and OMNI-Site Watcher to continuously monitor single-phase, 120 VAC power.

The voltage-sensing relay has an adjustable dropout voltage of 90 to 103 V. When the voltage drops below the dropout value, the relay on the PLS-1 opens, signaling the Local Environment Monitor.

If the power stays off longer than the fault duration, the LEM signals the OMNI-4000 software that there is an alarm condition. If you have the OMNI-Alert alarm notification system installed and the alarm is set to active, OMNI-Alert dials the contacts on its call list and notifies them about the condition.

The PLS-1 is designed to monitor the power for a single line. Using multiple PLS-1s, you can monitor additional circuits, zones, or rooms at your site. You can connect up to six PLS-1s to a single LEM.

Features

- ◆ Easy installation in new or existing sites
- ◆ Voltage-sensing relay
- ◆ General-purpose relay
- ◆ Mounting rail and sockets
- ◆ 90-day limited warranty

Electrical ratings

- ◆ Input: 120 VAC
- ◆ Dropout: 90 to 103 V
- ◆ Pickup: 105 V



Phase Detection Sensor (PDS-1)

Reliably detect phase loss in three-phase systems

Phason's Phase Detection Sensor (PDS-1) works with the Local Environment Monitor (LEM) and OMNI-Site Watcher to continuously monitor three-phase power.

The phase-monitoring relay has adjustable voltage (200 to 480 VAC), unbalance trigger (2 to 10 % variation), and trip delay (0.25 to 30 seconds) settings. When the voltage on a phase varies by more than the unbalance trigger percentage and for longer than the trip delay, the relay on the PDS-1 opens, signaling the LEM.

If the power stays off longer than the fault duration, the LEM signals the OMNI-4000 software that there is an alarm condition. If you have the OMNI-Alert alarm notification system installed and the alarm is set to active, OMNI-Alert dials the contacts on its call list and notifies them about the condition.

The PDS-1 is designed to monitor the power for a single line. Using multiple PDS-1s, you can monitor additional circuits, zones, or rooms at your site. You can connect up to six PDS-1s to a single LEM.

Features

- ◆ Easy installation in new or existing sites
- ◆ Phase monitoring relay
- ◆ General-purpose relay
- ◆ Mounting rail and sockets
- ◆ 90-day limited warranty

Electrical ratings

- ◆ Input: 200 to 480 VAC, 50/60 Hz
- ◆ Unbalance trigger: 2 to 10 %
- ◆ Trip delay: 0.25 to 30 sec



Regulated Power Supply (RPS)

Safe, reliable power for difficult environments

Phason's Regulated Power Supply (RPS) is a CSA-approved, Class 2 power supply. The RPS is designed to provide safe, regulated power (13.6 VDC and 24 VAC) for general applications. The rugged enclosure is able to withstand harsh conditions.

The RPS has a battery-backup option. The battery backup supplies enough power to maintain or slowly charge a 12 V gel cell battery (not included). If the incoming AC power fails, the battery provides power to the devices connected to the DC output terminal.

Features

- ◆ CSA approved
- ◆ Class 2 power supply
- ◆ AC and DC outputs
- ◆ Battery-backup option
- ◆ Rugged enclosure (corrosion resistant, water resistant, and fire retardant)
- ◆ Easy installation and maintenance-free design
- ◆ 90-day limited warranty

Electrical ratings

- ◆ Input
 - ◆ 115/230 VAC
 - ◆ 50 VA
 - ◆ 50/60 Hz
- ◆ Output
 - ◆ 24 VAC
 - ◆ 13.6 VDC
 - ◆ 15 W maximum
- ◆ Fuse
 - ◆ 1 A, 250 V fast-acting glass



NOTE: One RPS can provide power for up to 11 Local Environment Monitors.

High Temperature Probe (HTP)

Designed to withstand high temperatures and rugged conditions

The High Temperature Probe (HTP) is designed for temperatures ranging from 86 to 302°F (30 to 150°C). The HTP is useful for monitoring temperatures of equipment such as generators, or hot water tanks.

The HTP has a ring terminal probe for easy mounting and comes with a 6-foot weather, UV, and heat-resistant cable. Extension cable is available to extend the probe up to 500 feet.

Features

- ◆ Ring terminal for easy installation
- ◆ Rugged and durable design
- ◆ 6-foot heat-resistant cable
- ◆ 90-day limited warranty



Temperature range

- ◆ 86 to 302°F
- ◆ 30 to 150°C

If you have any questions about Phason's risk management and insurance solution or any of the products in this package, visit www.phason.ca or contact Phason. Our experts will be happy to assist you.

Phason Inc.

2 Terracon Place
Winnipeg, Manitoba, Canada
R2J 4G7

Phone: 204-233-1400
Fax: 204-233-3252

E-mail: support@phason.ca
Web site: www.phason.ca
