

Phason communication overview

Many Phason systems can be monitored and controlled from a computer. All networkable Phason systems feature automatic data collection. Automatic data collection saves you time and money because it eliminates the need to manually go to each device and record information. It also eliminates the human error involved in manual data collection.

All Phason networkable devices (for example, a ventilation control) communicate with the computer using an RS-232/485 communication converter and communication cable.

Communication channels

A communication channel is a continuous line of cable connecting all devices in the series, in other words, a “daisy chain”. Each device connects to the communication channel as shown below.

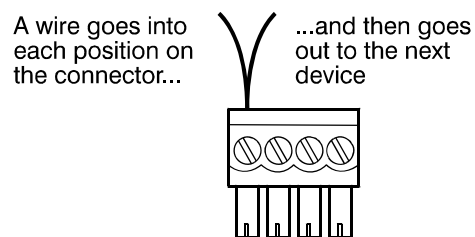

The last device on a communication channel must have the termination resistors in place or a termination module installed. For more information, see the installation guide for the particular device.

Phason uses two types of communication systems:

- ◆ Single-channel systems: MaxPro II, BinBoss, and SupraWare
- ◆ Multi-channel systems: All OMNI-4000 modules and devices

Single-channel systems

Single-channel systems can have up to 32 devices on the communication channel.

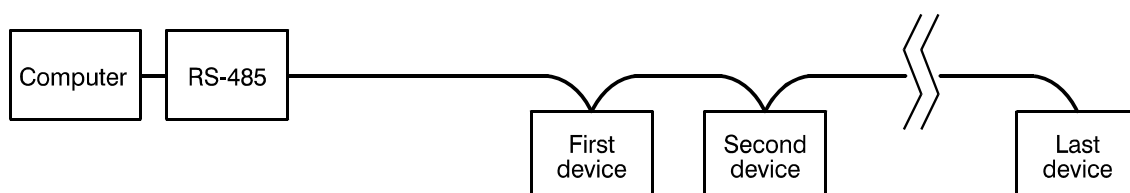

Multi-channel systems

The multi-channel OMNI-4000 system requires an OMNI Server. An OMNI Server has 8 communication channels and can communicate with up to 32 devices on each channel, for a total of 256 devices.

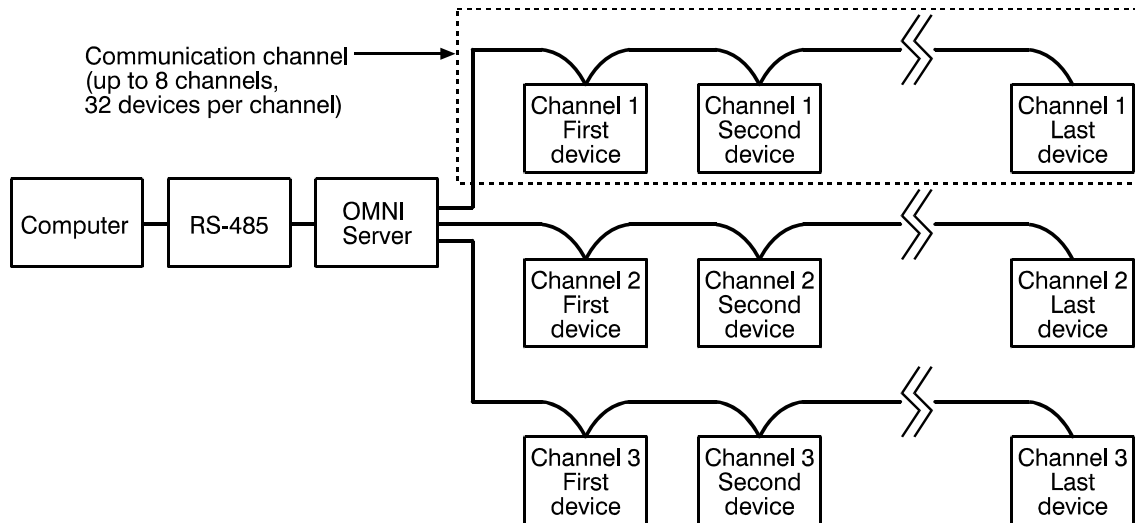

Communication cable requirements

The following types of cable are acceptable:

- ◆ Unshielded twisted pair (UTP), category 3 (CAT3) or category 5 (CAT5)
- ◆ Shielded twisted pair (STP), CAT3 or CAT5

Phason does not recommend other types of wire.

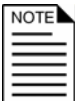

If you are using STP cable, you must follow the specific instructions in **Service Bulletin 24—Using shielded twisted pair (STP) cable to connect Phason networkable devices.**

Communication wiring

There are three possible connector types on Phason devices. The four-positions, **A B C D**, are common to all models. Some models have five positions and include **E** for common reference wiring. The six-position connectors that include position **1** are included on the RS-485A and OMNI Alarm Manager (OAM) only.

The proper connector alignment is shown below.

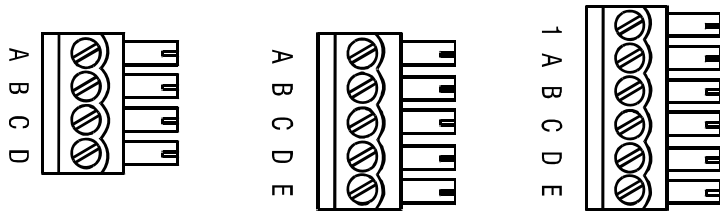

Using common reference wiring

Common reference wiring helps eliminate communication problems. The common reference wire normally connects to position E on the connector.

For controls having only four-position connectors, it is a good idea to leave the communication cable one foot longer than is needed for connecting to the terminals (A, B, C, and D). You can then use the extra length of wire to connect to a reference point on the circuit board in place of the E terminal.

For information about which terminal to use in place of the E terminal, see the user manual for the specific device, or contact Phason Customer Support.

Using consistent wiring

Using consistent wiring helps eliminate communication connection errors and makes troubleshooting much easier. Use the wire colors shown below when connecting all devices to the communication system.

Wire function	RS-485A wire colors	First device	All remaining devices
1 alarm signal ^①	1 white/green	1 white/green	1 white/green
A communication	A blue	A blue	A blue
B communication	B white/blue	B white/blue	B white/blue
C communication	C orange	C orange	C orange
D communication	D white/orange	D white/orange	D white/orange
E common reference ^②	E green	E green	E green

① Only for OMNI systems with an OMNI Alarm Manager
 ② Not available on all models

Common mistakes in communication wiring

- ◆ **Not using the correct type of communication cable**—the communication cable must be twisted pair cable, category 3 (CAT3) or category 5 (CAT5). You can use either unshielded twisted pair (UTP) or shielded twisted pair (STP) cable. Phason does not recommend other types of wire.

	<p>If you are using STP cable, you must follow the specific instructions in Service Bulletin 24—Using shielded twisted pair (STP) cable to connect Phason networkable devices.</p>
---	---

- ◆ **Not continuing the communication wiring properly**—all the devices on the communication channel must be connected in series (in a daisy-chain) and the wire must be continued properly from one device to the next. When continuing the communication wiring from one device to the next, the wires must be connected as shown below.

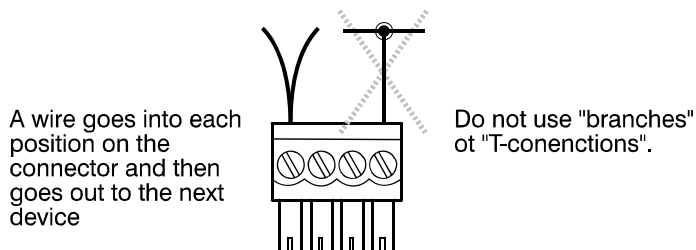

- ◆ **Not terminating the last device on the communication channel**—on all systems, the last device on the communication channel must have the termination resistors in place or a termination module installed.

The termination resistors are located on the circuit board of all networkable devices, except the Supra (the Supra uses a Termination Module). You must remove the termination resistors from all devices, except the last one on the communication channel.

The termination resistors on OMNI Power Blocks are in sockets on the Micro Board and can be removed and replaced if necessary. Termination resistors on all other models must be removed using wire cutters. For more information about the location of termination resistors, see the installation guide for your specific product.

If you remove the termination resistors from the last device by mistake, you will have to install a Termination Module on that device. The Termination Module connects to the communication socket on the last device. For information about Termination Modules, contact your dealer or Phason Customer Support.

- ◆ **Running the communication cable in the same conduit as, or beside AC power cables**—routing communication cable in the same conduit as, or beside AC power cables, can cause electrical interference and communication failures. Follow the guidelines below when routing communication cable.
 - ◆ Do not run the cable in the same conduit as AC power cables.
 - ◆ Do not run the cable beside AC power cables or near electrical equipment.
 - ◆ When crossing other cables or power lines, cross them at a 90-degree angle.

For more information about proper routing of communication cables, see **Service Bulletin 19**. Service Bulletin 19 discusses proper routing of data wires, including actuator feedback, communication, and other sensor cables.

For more information

1. **Read your user manual or installation guide**—each system’s user manual contains all the information for properly connecting the communication wiring.
2. **Read other service bulletins**—service bulletins, including the ones mentioned here, are available at www.phason.ca/tech
3. **Call Phason Customer Support**—if you cannot solve the problem *after reading your manual*, call Phason Customer Support. Phason’s specialists can help you track down and solve the problem. Make sure you have all your information (type of system, type of communication cable, serial numbers, etc.) before calling.